

NASA TECHNICAL NOTE



NASA TN D-3828

C.1

NASA TN D-3828

LOAN COPY: RETURN  
AFWL (WALL)  
KIRTLAND AFB, TX

0130681



TECH LIBRARY KAFB, NM

# OPERATIONAL FEATURES OF THE LANGLEY LUNAR LANDING RESEARCH FACILITY

*by Thomas C. O'Bryan and Donald E. Hewes*

*Langley Research Center*

*Langley Station, Hampton, Va.*





OPERATIONAL FEATURES OF THE LANGLEY LUNAR LANDING

RESEARCH FACILITY

By Thomas C. O'Bryan and Donald E. Hewes

Langley Research Center  
Langley Station, Hampton, Va.

NATIONAL AERONAUTICS AND SPACE ADMINISTRATION

---

For sale by the Clearinghouse for Federal Scientific and Technical Information  
Springfield, Virginia 22151 - Price \$2.00



## CONTENTS

	Page
SUMMARY . . . . .	1
INTRODUCTION . . . . .	1
SYMBOLS . . . . .	3
DESCRIPTION OF LUNAR-GRAVITY SIMULATION TECHNIQUE . . . . .	4
RESEARCH VEHICLE . . . . .	6
Configuration Features . . . . .	8
Pilots' Flight-Control Systems . . . . .	9
Fuel Supply System . . . . .	13
Automatic Balancing System . . . . .	14
GANTRY AND BRIDGE CRANE . . . . .	16
Gantry Structure . . . . .	16
Bridge Unit . . . . .	17
Dolly Unit . . . . .	19
Operational Limits . . . . .	21
CONTROL ROOM . . . . .	22
RESEARCH DATA RECORDING . . . . .	24
TEST OPERATIONS . . . . .	26
Preflight Checkout . . . . .	26
Flight Tests . . . . .	27
Postflight and Emergency Operations . . . . .	27
SYSTEM TEST RESULTS . . . . .	28
Step-Input Response . . . . .	28
Flight-Maneuver Response . . . . .	30
Observations on Facility Operations . . . . .	34
CONCLUDING REMARKS . . . . .	35
REFERENCES . . . . .	36

# OPERATIONAL FEATURES OF THE LANGLEY LUNAR LANDING RESEARCH FACILITY

By Thomas C. O'Bryan and Donald E. Hewes  
Langley Research Center

## SUMMARY

The design features of the Langley lunar landing research facility (LLRF) are described. This facility provides the capability for flying a piloted vehicle in a simulated lunar-gravity field and is presently being used to obtain detailed information relative to the flight dynamics of the Apollo lunar module. Operational procedures and results of a typical flight test are discussed to show the manner in which the facility is utilized. Some of the operational characteristics of the servocontrolled systems which produce the simulated lunar gravitational field are illustrated.

Over 150 flight-test operations have been performed to date with 9 research pilots and astronauts, who have all reported the sensations of actual free flight during the test operations. Approximately 2 minutes of sustained flight are possible by use of the hydrogen peroxide main rockets in the vehicle. This time capability exceeds the time required for the Apollo lunar module to accomplish its terminal maneuver or to touch down on the lunar surface from about 150 feet (45.7 meters). Continuous monitoring of the servo-systems has indicated satisfactory simulation of the lunar gravity, and pilots of the vehicle report negligible effects of the visual cues afforded by the facility structure.

## INTRODUCTION

The successful performance of the touchdown phase of the Apollo lunar module and of other future manned vehicles intended for lunar and planetary exploration depends to a great extent on provision of satisfactory pilot handling qualities. Because present-day flight experience with manned spacecraft is limited to orbital vehicles, the only basis for establishing handling-quality criteria for surface-landing vehicles is the experience gained with earthbound aircraft and with several fixed- and moving-base simulators in which computers, simulated cabins, and optically generated visual references are utilized. Recently, two new simulators, providing actual flight experience with operational vehicles, have become available to assist in establishing and refining the spacecraft criteria. One of these simulators is the Lunar Landing Research Vehicle (LLRV) based at Edwards Flight Research Center (see ref. 1) and the other is the lunar landing

research facility (LLRF) at the Langley Research Center shown in figure 1. The operational flight envelopes for these two research tools are determined by the features unique to each design, but the two simulators are complementary to each other so as to provide the means for correlating actual flight-test experience. This is a descriptive report of the LLRF covering the lunar-gravity simulation technique, the detail design of the various components, and the operational aspects of the Langley facility. A description of a piloted model of the lunar-gravity simulation system used to determine the feasibility of the lunar gravitational simulation system for the LLRF is presented in reference 2.

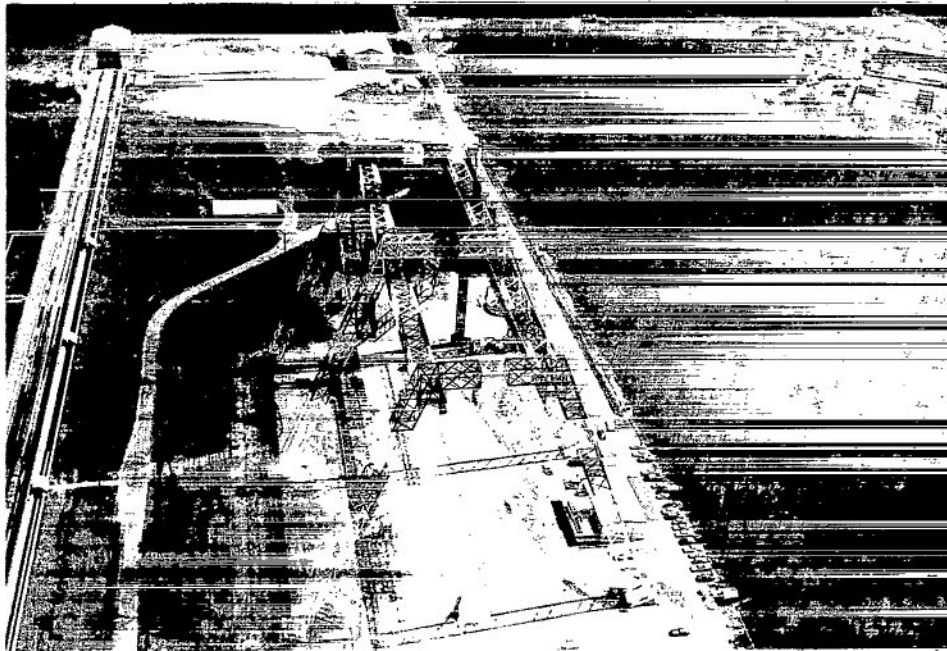

L-65-3002  
Figure 1.- Aerial photograph of the Langley lunar landing research facility as seen -  
looking toward the east.

## SYMBOLS

Measurements for the dimensional quantities presented herein were originally taken in the U.S. Customary System of Units but are presented also in the International System (SI). Details concerning the use of SI and conversion factors relating the two systems are given in reference 3.

$K_1, K_2, K_3, K_4, K_5, K_6, K_7$	rate and rate-integral feedback gains
S	differential operator
$H_2O_2$	hydrogen peroxide
$N_2$	gaseous nitrogen
x,y,z	vehicle-body-oriented longitudinal, lateral, and vertical distance, respectively, feet (meters)
X,Y,Z	down-range, cross-range, and vertical distance, respectively, feet (meters)
$\dot{x}, \dot{y}, \dot{z}$	vehicle-body-oriented longitudinal, lateral, and vertical velocity, respectively, feet/second (meters/sec <sup>2</sup> )
$\dot{X}, \dot{Y}, \dot{Z}$	down-range, cross-range, and vertical velocity, respectively, feet/second (meters/second)
$\ddot{x}, \ddot{y}, \ddot{z}$	vehicle-body-oriented longitudinal, lateral, and vertical acceleration, respectively, feet/second <sup>2</sup> (meters/sec <sup>2</sup> )
$\ddot{X}, \ddot{Y}, \ddot{Z}$	down-range, cross-range, and vertical acceleration, respectively, feet/second (meters/sec)
$\theta$	angle of pitch, deg
$\dot{\theta}$	angular velocity in pitch, deg/sec
$\ddot{\theta}$	angular acceleration in pitch, deg/sec <sup>2</sup>
Subscript:	
max	maximum

## DESCRIPTION OF LUNAR-GRAVITY SIMULATION TECHNIQUE

A basic capability that the lunar landing research facility provides is that a pilot is permitted to maneuver the vehicle, shown in figure 2, by means of main lifting and attitude control rockets, anywhere within the limits of the facility while under the influence of a simulated lunar gravitational field. Simulation of the gravity field is achieved by employing an overhead suspension system, which provides a vertical lifting force equal to  $5/6$  of the vehicle weight by means of cables acting through the center of gravity of the vehicle so as to cancel effectively all but  $1/6$  of the gravitation force of the earth. The cables are attached to the vehicle through a gimbal system which provides freedom of motion in pitch, roll, and yaw. The upper ends of the cables are attached to a hoist unit on the traveling bridge crane shown in figure 3. This hoist employs a servocontrolled hydraulic drive system which automatically drives the cables up and down in response to the vertical motions of the vehicle generated by pilot control of the main lifting rockets.

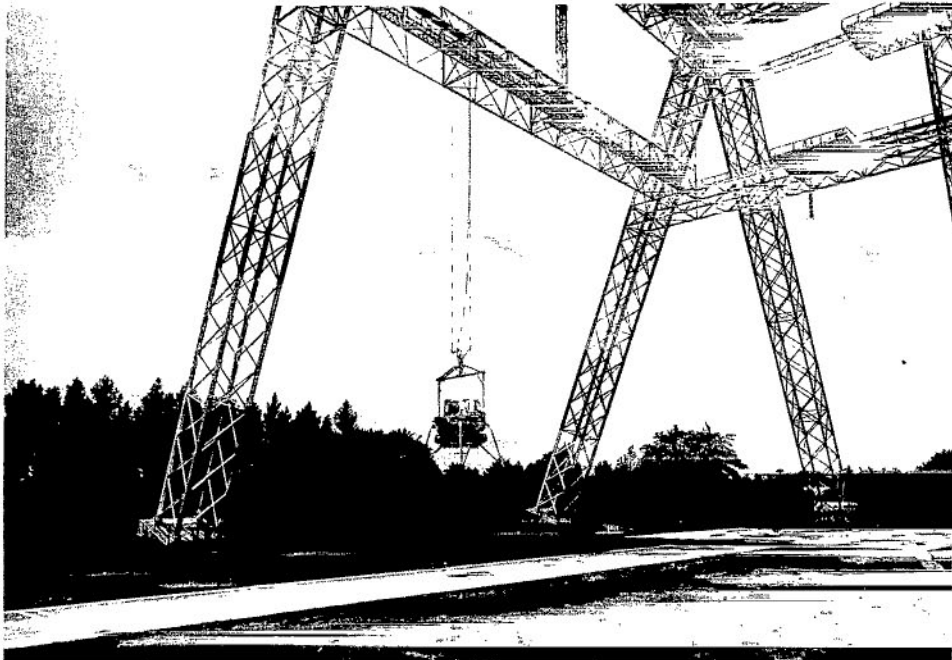

L-65-4818

Figure 2.- Research vehicle being flown during simulated lunar-gravity operation.



Load cells in the suspension system provide a signal proportional to the tension in the cables for controlling the servo-drive unit.

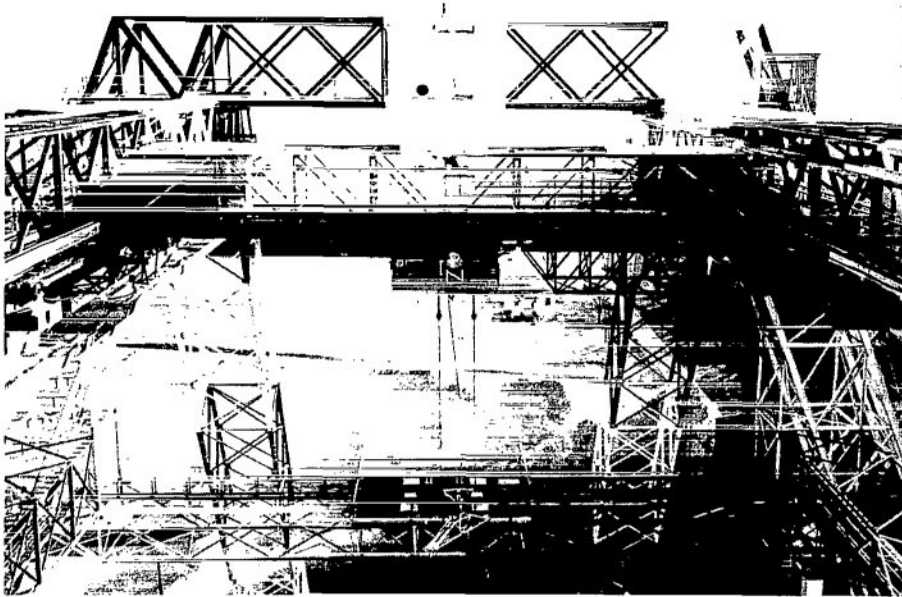

Figure 3.- View of traveling bridge crane mounted on gantry structure. L-66-1690

To maintain vertical alinement of the support cables as the vehicle moves about horizontally in response to pilot pitch and roll commands, a traveling bridge crane and an underslung dolly follows the vehicle automatically and stays directly over the vehicle at all times. These units are driven by servocontrolled hydraulic systems (similar to that employed in the vertical hoist unit). The down-range and cross-range motions are controlled by dolly-mounted cable-angle sensors that detect angular deviations of the cable from the vertical and separate these deviations into components in the down-range and cross-range directions.

The detailed descriptions of the various components of this facility are given in subsequent sections of this report.

Two operational modes of the simulation technique were developed; the first mode, which does not actively utilize main lifting rockets, is used primarily for pilot indoctrination and exploratory tests of new combinations of control-system parameters, and the second mode which employs operation of the main rockets is used for final evaluation of specific conditions. Elimination of the main rockets for the first mode, hereinafter referred to as the simulation mode, permits all the onboard fuel to be utilized for the attitude control rockets. Continuous operation in excess of 20 minutes is achieved by

operation in the first mode, in contrast to the approximate 2-minute duration when the main rockets are in use for the second mode of operation. This second mode is hereinafter referred to as the operational mode. The flight time of 2 minutes in this mode is in excess of that required for the Apollo lunar module to accomplish the terminal or touch-down phase of its landing maneuver from about 150 feet (45.7 meters).

For the simulation mode, thrust of the lifting rockets is simulated by generating an electrical signal proportional to the commanded thrust and using a potentiometer connected to the throttle control lever. This signal is then added to the signal from the load cells which normally command a cable tension equal to  $5/6$  the weight of the vehicle. In this manner, the vertical-hoist unit is commanded to produce an additional force on the vehicle through the cables closely approximating the vertical component of the rocket thrust commanded by the pilot. The acceleration normally produced by the horizontal component of the main rockets when the vehicle is at a pitched or rolled attitude is produced in the absence of the rocket thrust by adding, to the cable-angle-sensor signals, electrical biasing signals proportioned to the pitch and roll angles so as to command a cable angle offset from the vertical equal to about  $1/6$  the corresponding vehicle attitude angle. In order to produce the commanded offset cable angle, the bridge or dolly must accelerate at a level consistent with the angular attitude of the vehicle. Because of the pendulous action of the cables, the approximate nature of the additional command signals to the servo drive systems, and the requirement for the vertical drive system to accelerate the entire mass of the vehicle, some errors in the response of the vehicle are associated with this mode. However, the advantage of a greatly increased flight duration exceeds the disadvantage of small dynamic errors for the indoctrinary and exploratory phases of the facility operation.

The operational mode provides greater realism of flight by eliminating the dynamic errors associated with the simulation mode of operation and also by adding the audio cues of the main rockets' firing and the constraint of limited fuel and flight time. The latter two factors produce a pilot stress level which is greater than that imposed by the simulation mode and probably is much closer to that imposed by an actual lunar landing.

## RESEARCH VEHICLE

The piloted vehicle, shown close up in figure 4, was designed as a research tool so that many of the system parameters and design features could be varied as part of a general research program on the handling qualities of lunar flight and landing vehicles. Control-system adjustments with minimum modification are provided by the use of analog computers mounted on the vehicle. A list of the physical characteristics of the vehicle and the ranges of variable system parameters is given in table I.

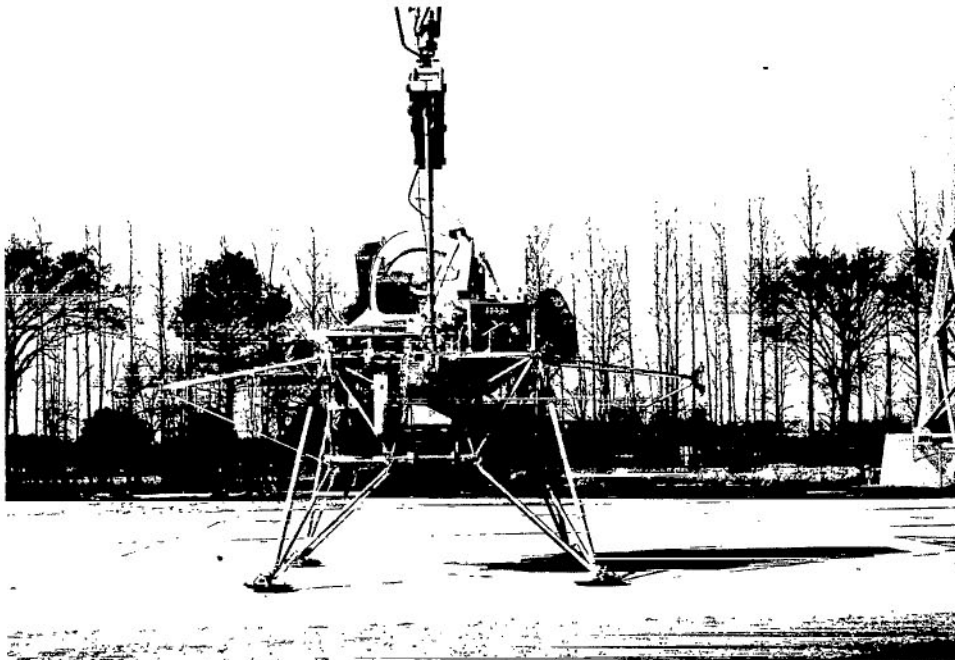

Figure 4.- Closeup of research vehicle.

L-66-2144

TABLE I.- PHYSICAL CHARACTERISTICS AND DESIGN FEATURES OF THE LLRF VEHICLE

Total weight . . . . .	12 000 lbm (5443 kg)
Fuel . . . . .	90 percent H <sub>2</sub> O <sub>2</sub>
Maximum fuel capacity . . . . .	3100 lb (1406 kg)
Maximum nitrogen capacity . . . . .	19 ft <sup>3</sup> at 3000 psi (0.54 m <sup>3</sup> at 20 684 kN/m <sup>2</sup> )
Moment of inertia:	
Pitch . . . . .	3540 slug-ft <sup>2</sup> (4800 kg-m <sup>2</sup> )
Roll (including gimbal support) . . . . .	4770 slug-ft <sup>2</sup> (6467 kg-m <sup>2</sup> )
Yaw (including gimbal support) . . . . .	4750 slug-ft <sup>2</sup> (6440 kg-m <sup>2</sup> )
Maximum height . . . . .	14.75 ft (4.5 m)
Pilot's eye level above ground . . . . .	13.17 ft (4.0 m)
Landing gear:	
Span . . . . .	11.5 ft (3.5 m)
Shock strut type . . . . .	Air-oil (honeycomb, backup)
Shock strut stroke . . . . .	1 ft (0.3 m)
Maximum load factor, g-units (earth) . . . . .	4
Main lifting thrust . . . . .	600 to 6000 lbf (2.669 to 26.689 kN)
Control moments:	
Pitch . . . . .	100 to 2000 ft-lb (136 to 2712 m-N)
Roll . . . . .	128 to 2560 ft-lb (174 to 3471 m-N)
Yaw . . . . .	135 to 1350 ft-lb (183 to 1830 m-N)
Maximum attitude angles:	
Pitch . . . . .	±30°
Roll . . . . .	±30°
Yaw . . . . .	±360°

The research vehicle is somewhat smaller than the Apollo lunar module and the pilot is sitting down rather than standing up; however, the linear and angular accelerations produced by the main and the attitude rockets are comparable. Consequently, the vehicle permits an accurate duplication of lunar module flight characteristics.

### Configuration Features

The basic structure for the vehicle is a box-like frame 4 feet (1.2 m) deep by 8 feet (2.4 m) square to which are externally attached the four landing gear legs, the pilots' compartment, the gimbal suspension assemblies, and the propulsion system. The gimbal assemblies house the pitch gimbal bearings, which carry the cable loads into the vehicle structure and allow the vehicle to rotate freely in pitch within the limits of  $30^{\circ}$  pitch up and  $30^{\circ}$  pitch down. Roll and yaw freedom is provided by the whiffletree, which is discussed subsequently.

Each landing-gear leg employs a main shock strut, such as that used on helicopters, attached by a pivot joint to the corner of the vehicle frame. The strut is stabilized by two articulated arms attached to the bottom of the vehicle frame. A 1-foot-diameter (0.3 m) aluminum landing pad is attached at the apex of the landing-gear leg by means of a ball-socket joint, which allows the pad to align itself with the slope of the terrain when ground contact is made. The pad is spring loaded, as shown in figure 5, so as to rotate on the ball-socket joint as the vehicle leaves or makes contact with the ground, whereby

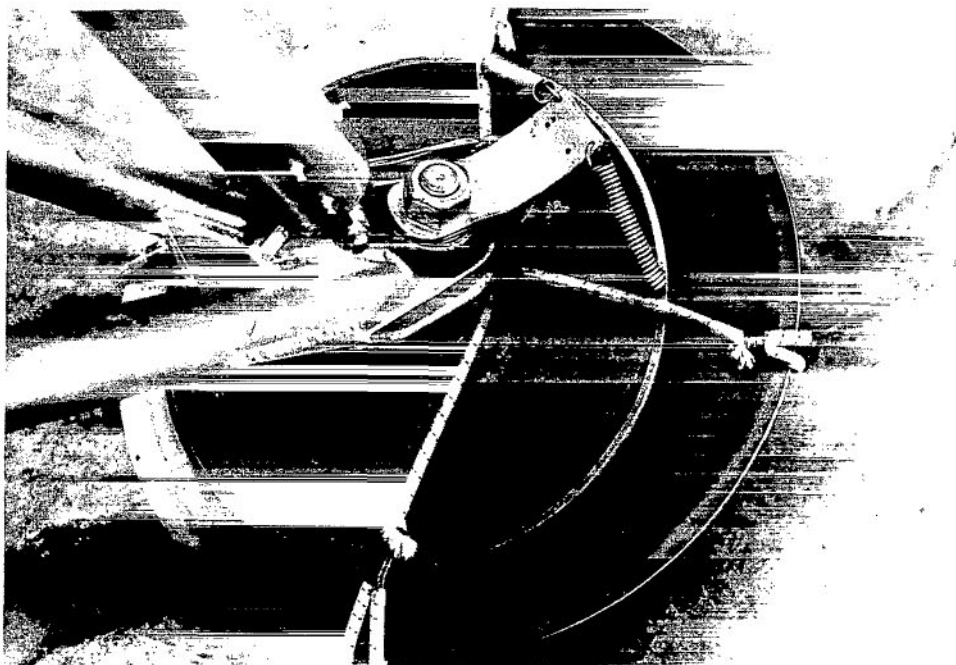

Figure 5.- Closeup view of landing-gear pad and slipper.

L-66-2192

electrical switches, one on each leg, are caused to open and close. The purpose of the switching action is to short circuit the integrating amplifiers in the various servo systems (discussed in subsequent sections) so as to insure stable operation of the servo systems with the vehicle on the ground. Also shown in figure 5 is a 1.5-foot-diameter (0.46 m) steel pad that was incorporated as a "slipper" so as to reduce high frictional forces between the aluminum pad and the concrete landing surface. These high forces prevent the shock strut from functioning properly. The shock-strut assembly incorporates aluminum honeycomb elements that begin to crush when the vehicle vertical velocity exceeds 10 feet/second (3.05 m/sec). Sufficient stroke and energy absorption is provided by the honeycomb to permit landing with a vertical velocity of about 17 feet/second (5.18 m/sec) without exceeding the vehicle design loading.

The pilots' compartment consists of the front portion of a helicopter modified to be mounted directly on the vehicle frame. A plot of the field of view from the right-hand seat is shown in figure 6. The instrument panel shown in figure 7 is considered to be a basic set of instruments for lunar landing and is arranged for primary pilot control from the right-hand seat. These instruments display roll, pitch, and yaw attitudes and angular rates, and the coordinate linear positions and velocities relative to the landing site. A three-gimbal stable platform and body-axis-mounted rate gyros provide driving signals for these displays.

Other quantities pertaining to vehicle systems operation displayed on the panel include fuel flow and fuel quantity, main-engine manifold pressure, and electrical supply voltages. An oxygen breathing system employing standard military aircraft oxygen supply equipment is provided for the occupants of the pilots' compartment. This system is provided as a safety measure to prevent the pilot from inhaling the noxious products of the rocket motor exhaust arising from the decomposition of hydrogen peroxide fuel. A circulating cold water suit is provided for the pilots to wear on days when the weather conditions result in cockpit temperatures, inside the closed plexiglass bubble, above about 85° F. Electrical power is supplied in the vehicle during flight by a group of nickel-cadmium batteries located ahead of the pilots' compartment.

### Pilots' Flight-Control Systems

The pilots' primary flight controls are shown in figure 7. The main lifting engine throttle lever, formerly used as the helicopter collective pitch control, is operated by the left hand, either from the right-hand or left-hand pilot's seat. There are currently two readily interchangeable attitude control arrangements provided in the vehicle. The first is the two-axis side-arm controller, shown at the right-hand seat, which is used in conjunction with the foot-operated yaw pedals. The second arrangement is the three-axis controller, shown at the left-hand seat, and is similar to the controller used in the

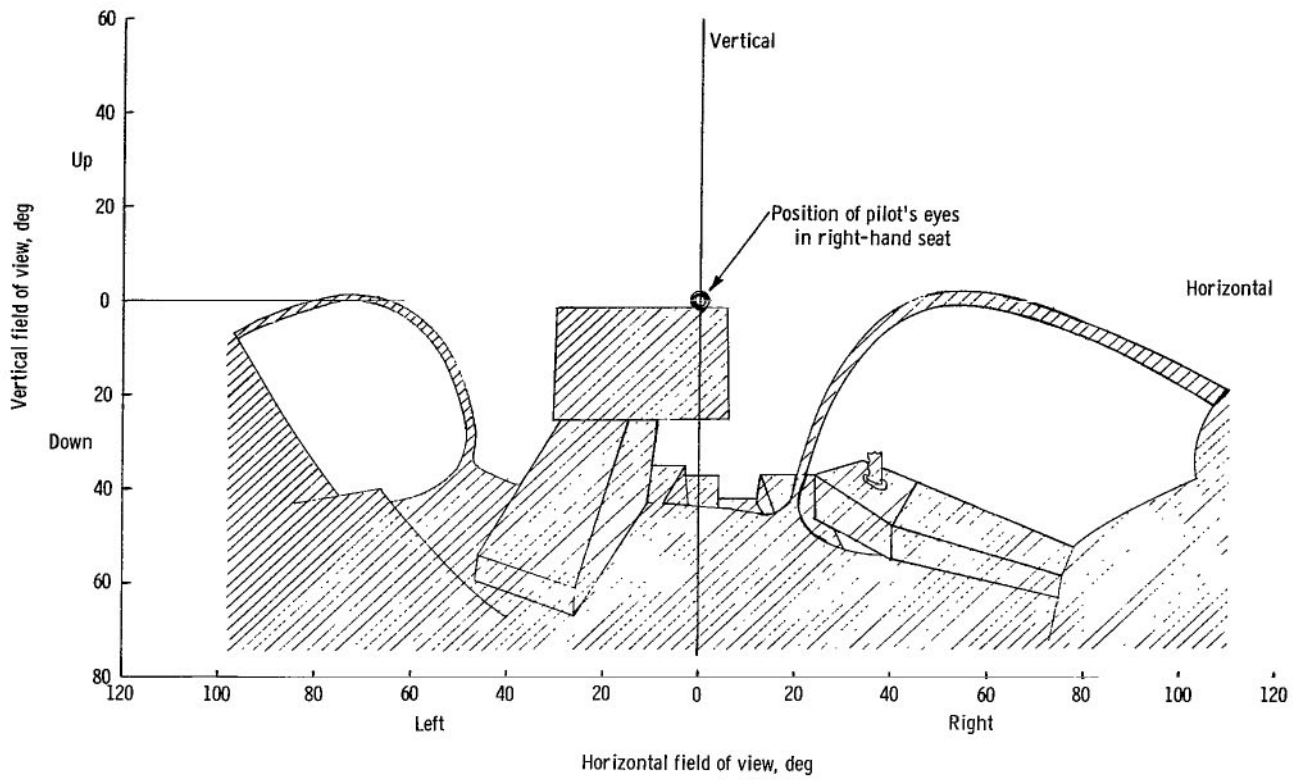

Figure 6.- Plot of field of view from right-hand seat of pilots' compartment.

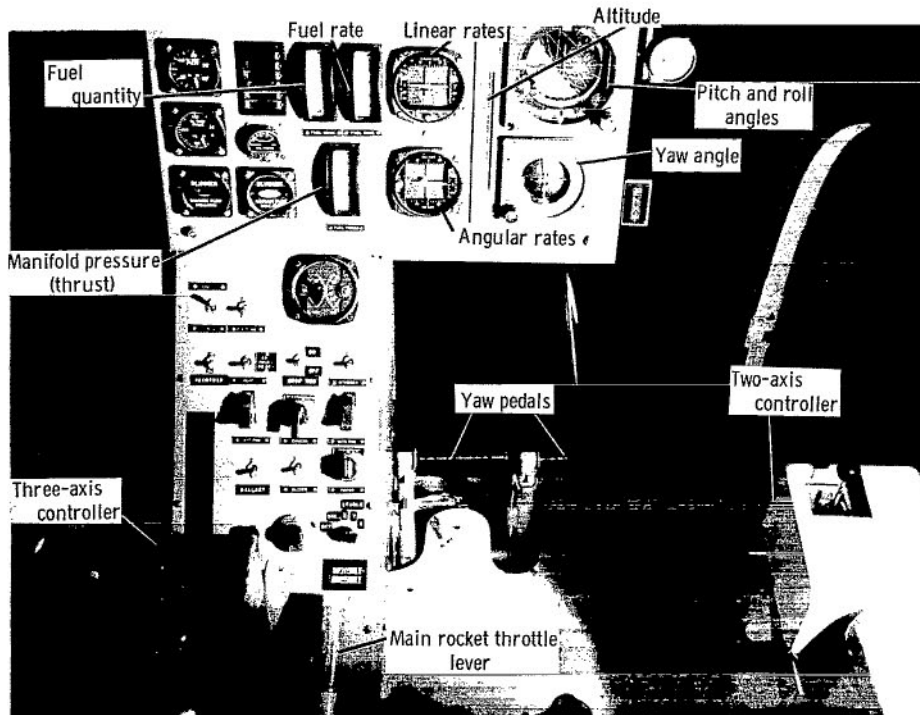
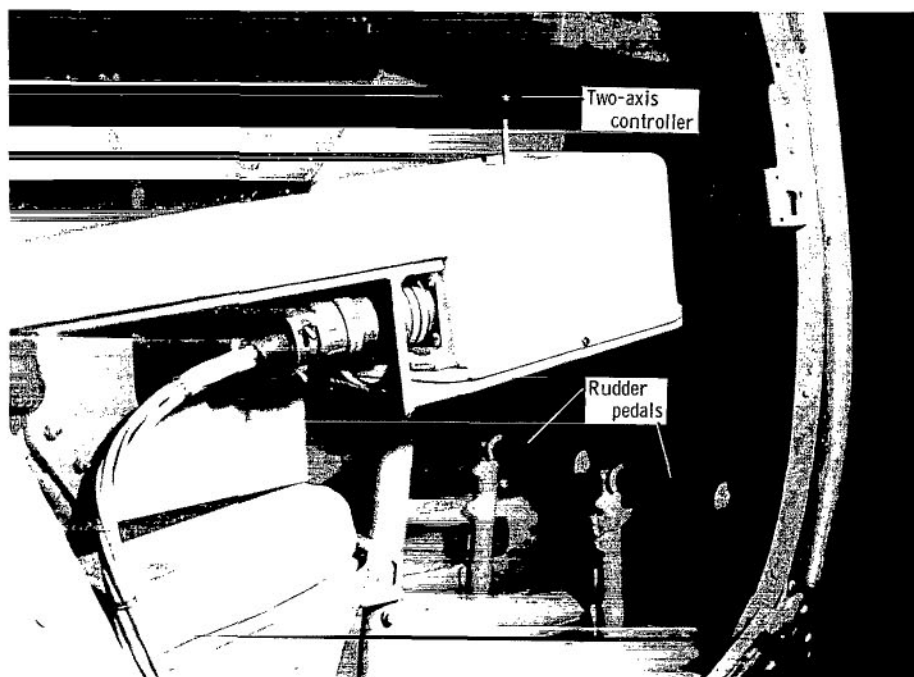

Figure 7.- Pilot's instrument panel. L-65-4522.1

lunar module. The yaw pedals are locked when the three-axis controller is being used and pilot's yaw-control input consists of a twisting wrist motion about the vertical axis of the control stick. Closer details of these two control arrangements are shown in figures 8 and 9.

The pitch-control system of the vehicle is illustrated diagrammatically in figure 10. This system is typical for all three axes. Attitude-control torques are generated by twenty 25-pound to 125-pound (111 to 556 N) thrust rocket motors located around the periphery of the vehicle frame. The multiplicity of motors, eight for pitch, eight for roll, and four for yaw, was used to provide flexibility in the research operations. These motors can be ground adjusted over the thrust range to provide a wide range of angular accelerations about each of the control axes. The motors are operated in an on-off or bang-bang fashion by solenoid-operated valves, which obtain their firing signals when the sum of the pilot-input control signals and the selected feedback signals fed into the electronic relay switch unit exceeds a given voltage level. This voltage level, which determines the system dead band, is preset by the pilot on a control console in the pilots' compartment. An additional dead band of  $\pm 1^\circ$  of controller stick travel is provided for each axis of control. Diode limiters prevent the signal from the controller passing until the voltage output equivalent to  $1^\circ$  of displacement is exceeded. A dead band is required in a system of this type to prevent excessive fuel consumption as a result of limit-cycle operation and inadvertent pilot control inputs.



L-65-4520.1

Figure 8.- View of two-axis controller (pitch and roll control) and rudder (yaw) pedals.

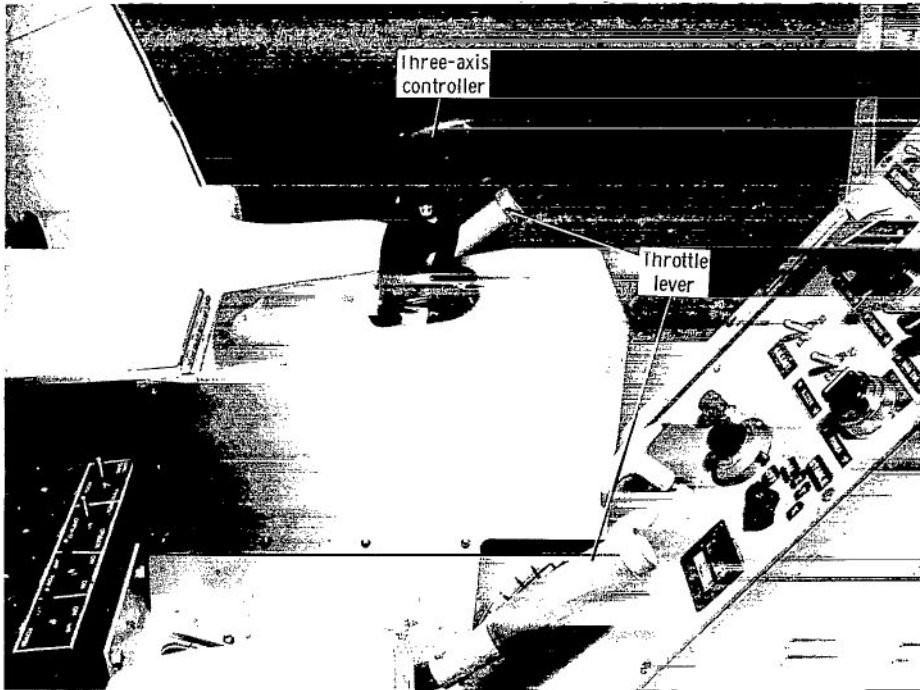

L-65-4519.1

Figure 9.- View of three-axis controller for combined pitch, roll, and yaw control.

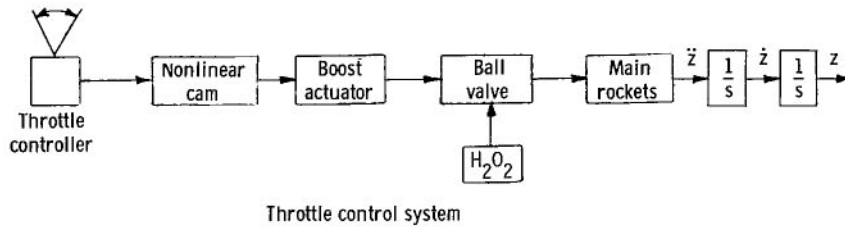
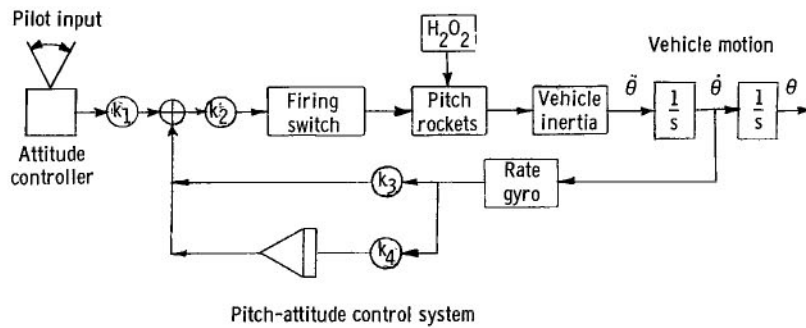

Figure 10.- Schematic diagrams of pitch-attitude and the throttle control systems for research vehicle.



The feedback signals consist of the angular rate and the integral of the angular rate and are used to provide different types of attitude-control systems to be evaluated in the research program. The gains of the signals can be individually adjusted by the pilot. With both signal gains set at zero, the system operates as an open-loop acceleration-command system which provides a constant and continuous angular acceleration as long as the pilot's control stick is deflected outside the dead band. With the rate feedback gain adjusted to a finite value, the system operates as a rate-command system in which displacement of the control stick results in a corresponding angular velocity after the attitude motors have fired momentarily. This system limits the maximum angular rate that the vehicle can achieve and also damps angular disturbances which produce velocities outside the equivalent rate dead band of the system.

Addition of the rate-integral signal produces an attitude-command system which generates a change in vehicle attitude directly proportional to displacement of the pilot's hand controller. The attitude engines fire until the attitude error resulting from the stick displacement and the ensuing angular rates have been reduced to less than the corresponding rate and attitude dead bands.

Control of the main-rocket thrust through a range of about 600 to 6000 pounds force (2.669 to 26.689 kN) is achieved by means of the throttle control system, also diagrammed in figure 10. A pneumatic boost actuator positions a ball valve in the fuel supply line immediately ahead of the main rockets in response to the pilot's throttle movements. A push-pull cable from the throttle operates the actuator through a non-linear cam used to compensate the nonlinear flow characteristics of the ball valve thereby achieving a linear throttle-position-to-rocket-thrust relationship.

### Fuel Supply System

A schematic of the fuel system of the vehicle is given in figure 11. Pressurized nitrogen gas at 3000 psi (20 648 kN/m<sup>2</sup>) is stored in six titanium pressure tanks equipped with a pressure relief valve set at 3250 psi (22 400 kN/m<sup>2</sup>). This gas is used to pressurize the four interconnected stainless-steel fuel tanks at 675 psi (4654 kN/m<sup>2</sup>) through a dome-loaded regulator-vent valve and a hand-operated isolation valve. A pressure relief valve set at 700 psi (4826 kN/m<sup>2</sup>) is used to prevent overpressurization of the tanks in case of the nitrogen regulator malfunction.

The fuel tanks have a total capacity of about 3100 pounds (14062 kg) of 90 percent hydrogen peroxide which is used to operate the main lifting rockets, the attitude-control system, and the pitch-trim system. Total fuel flow is measured in the main fuel line by an in-line free-rotor flowmeter employing magnetic pickup. The fuel-flow signal is integrated electronically to determine the quantity of fuel used. Pneumatically operated fail-safe valves are used in the fuel lines supplying the main engines and attitude-control

system to permit fuel cutoff either by the pilot or from the control room in cases of emergency and to insure safety while the crew is handling the vehicle. Hand-operated ball valves located just upstream of the main motors are utilized as an additional safety factor for vehicle handling prior and subsequent to a flight.

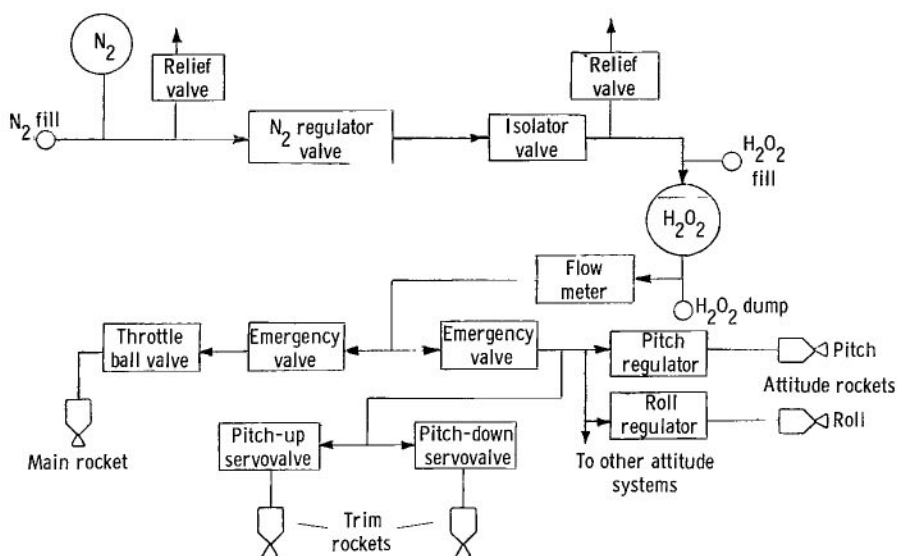

Figure 11.- Schematic diagram of the fuel system for the research vehicle.

Pressure of the fuel used in the pitch, roll, and yaw branches of the attitude-control system is regulated independently by dome-loaded regulators. Firing of the attitude engines is controlled by in-line solenoid-operated valves immediately ahead of each attitude rocket. A number of hand-operated valves are located in the low spots of the system to permit complete drainage of the fuel from the vehicle.

The fuel system utilizes stainless steel throughout to provide compatibility with the hydrogen peroxide fuel and the piping and valves are dimensioned to allow flow rates of 50 pounds per second (22.7 kg/sec) to the main engines.

System pressures are displayed on the pilot's instrument panel and also at the mechanic's panel attached to the frame at the rear of the vehicle. Adjustment of all the pressure regulators is made at the mechanic's panel and operation of the emergency valves is controlled by the pilot.

#### Automatic Balancing System

Because the mass of fuel used during a given flight represents about 25 percent of the total mass of the vehicle, the problem of center-of-gravity shift caused by fuel consumption and fuel transfer within the tanks while the vehicle is pitched and rolled is

extremely critical. The severity of this problem is illustrated by the fact that the moments generated by the shifting fuel can exceed the test-control moments in some cases by a factor of 10. The magnitude of this problem is greater in an earth simulation of lunar gravity and is minimized in the actual lunar landing situation inasmuch as the lunar weight of the fuel will be very much less and there will be essentially no tendency of the fuel to shift with the attitude changes. Several steps were taken in the original design of the vehicle and in subsequent vehicle modifications to reduce the effects of center-of-gravity shift.

For the purpose of minimizing the vertical center-of-gravity shift due to fuel consumption, the four cylindrical fuel tanks were located as close to the vehicle center of gravity as possible; in addition, an automatic ballast mechanism, which moves a weight vertically with a compensative motion, was developed. This ballast mechanism, located on the frame of the vehicle, consists of a 250-pound (113.4 kg) ballast box riding on vertical tracks and driven by a servocontrolled system, which is positioned in response to a pulsed electrical signal derived from the fuel flow measuring system.

The tanks, alined in the fore-and-aft direction, were compartmented and heavily baffled to minimize fuel transfer from one end to the other as the vehicle is pitched. These precautions to limit the horizontal shift of fuel were not adequate for pitching motions because of the relatively long duration of large pitch angles used in flight maneuvering; the gravity gradient within the tanks allowed only the fuel in the higher end of the tanks to flow to the rocket motors. Consequently, the rocket-powered pitch-trim system, shown schematically in figure 12, was installed on the vehicle. (See also fig. 4.) This system, by producing an opposing moment with the appropriate pair of boom-mounted rockets, compensates for the moment due to fuel shift. The thrust levels of the rocket pairs are modulated from an idling thrust of about 30 pounds (133 newtons) to the maximum of 125 pounds (556 newtons) by the action of servocontrolled throttling ball valves. The servos for the two separate valves obtain their positioning signals from an angular accelerometer alined with the pitch axis of the vehicle. Stability and minimum system

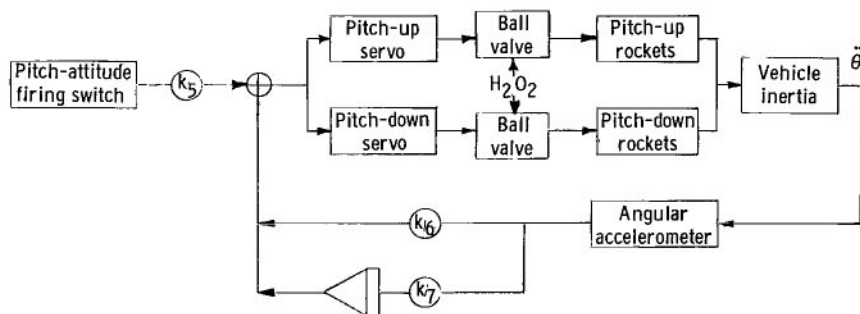

Figure 12.- Schematic diagram of the automatic pitch-trim system.

error are provided by combining the pitch-acceleration signal with the integral of the pitch signal. A uniform and nearly linear variation from zero to maximum trimming moment in either direction is achieved by moving only one throttle valve at a time and holding the other at its idle position. This action avoids having to shut off one pair of rockets while the other is turned on, so that an undesirable discontinuity in rocket operation is avoided.

In order to prevent cancellation of pilot-applied pitch controls by this system, a calibrated biasing signal corresponding to the commanded acceleration is added whenever the pitch-attitude control rockets are fired. Since the action of this system is always to seek either a zero or a commanded pitch-acceleration condition, the system has the additional desirable feature of automatically compensating for extraneous moments acting on the vehicle such as those produced by winds and pilot body motions.

## GANTRY AND BRIDGE CRANE

That part of the facility which supports the vehicle and follows its linear motions consists of a gantry structure and a traveling crane. The traveling crane consists of a bridge structure that travels the length of the gantry and an underslung dolly that travels the width of the bridge.

### Gantry Structure

The gantry structure, shown in figure 1, is oriented in the east-west direction and is composed of truss elements arranged with four sets of inclined legs that provide adequate clearance for any pendulous motion of the vehicle which could develop. An elevator enclosed in a shaft at the east end provides access to the overhead equipment, and catwalks permit all parts of the structure to be inspected at close range.

The structure is about 240 feet (73 m) high with two 400-foot (121.9-m) long tracks 72 feet (22 m) apart at the 220-foot (67-m) elevation. Each track is a flat surface 18 inches (46 cm) wide coated with an epoxy paint embedded with carborundum particles to provide good traction of the bridge rubber-tired drive wheels. The structure is painted in an alternating pattern of orange and white colors at about 40-foot (12.2-m) intervals to meet U.S. government regulations relative to aerial structures. Some of the orange sections on lower portions of the legs were omitted to minimize the possibility that the known distances of the alternating color bands might provide the vehicle pilots with optical cues to their altitude. The operational area underneath the gantry shown in figure 2 is paved with a 30-foot (9 m) wide concrete strip to minimize jet-blast effects and fuel-spillage problems.

## Bridge Unit

The bridge unit shown in figure 3 is composed of a tubular box-frame structure, 10 feet by 10 feet by 62 feet (3 by 3 by 19 m), supported at both ends by four-wheeled truck assemblies utilizing standard 52-inch-diameter (1.3 m) heavy-duty truck tires. Total span of the bridge is 72 feet (21.9 m) between center lines of the two wheel assemblies, which are driven independently by the servocontrolled hydraulic drive systems mounted in each end of the bridge structure. The two lower span members of the bridge structure form a track which supports the dolly unit and permits it to move in the cross-range direction.

Each bridge drive unit is composed of a constant-speed induction electric motor, rated as 250 horsepower (186 500 watts) driving a variable stroke hydraulic pump which is in turn directly coupled to two constant-displacement hydraulic motors of the same size and rating as the pump. (See fig. 13.) Each motor is geared to two of the drive wheels through a 4.5 to 1 pinion-bull gear power train. The hydraulic-fluid circuit is a closed-loop system with direct connections between inlet and outlet ports of the pump and motors. This system utilizes 3-inch (7.6-cm) stainless-steel pipe that is pressure tested to 9000 psi (62 053 kN/m<sup>2</sup>). Maximum operating pressure is approximately 3000 psi (20 682 kN/m<sup>2</sup>) regulated by pressure relief valves in the hydraulic motors. This hydraulic circuit is supercharged by means of an auxiliary pump driven by the electric motor. An elevated 30-gallon (0.09 m<sup>3</sup>) sump is used to provide makeup fluid and to receive servovalve, pump, and motor-case leakage.

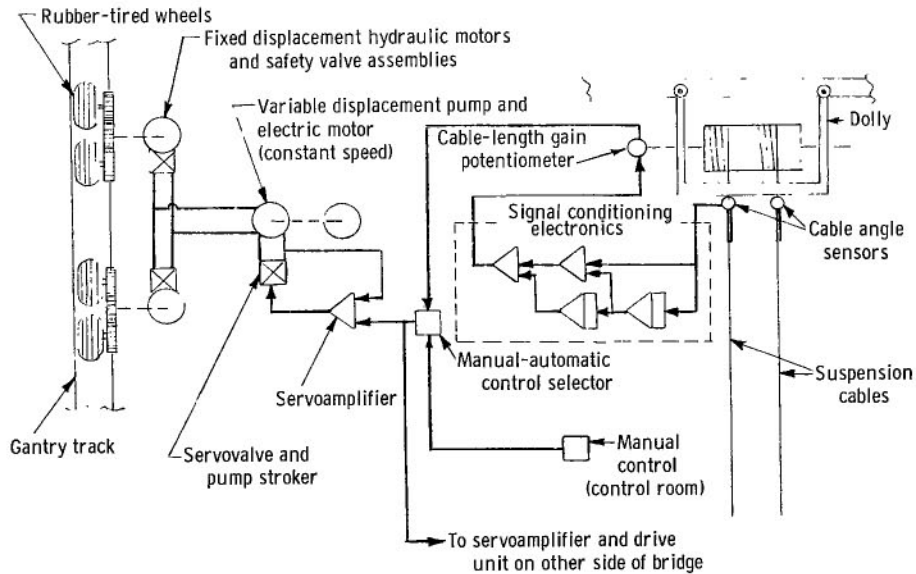

Figure 13.- Schematic diagram of bridge drive unit showing basic electronic and hydraulic circuits.

Control of each hydraulic drive unit is provided by a servo-operated hydraulic valve, which positions the drive-pump stroker and thereby regulates the pump flow output and, consequently, the bridge's speed and direction. An additional set of servo-operated safety valves, located in each hydraulic motor, bypass the flow from each motor through internally mounted pressure-relief valves to provide a closely regulated braking force for either a normal or an emergency braking operation. During this action the pump stroker is also automatically returned to its zero-stroke position and the pump-outlet port is ported directly to the inlet port to unload the pump.

Electric power for the induction motors is carried from the gantry to the bridge by means of bus bars mounted parallel to and directly over the bridge track on one side of the gantry and a trolley-collector assembly mounted on the same side of the bridge. Electric signals for control of the servo-operated hydraulic valves as well as several other functions are carried to the bridge from the gantry by a long trailing cable which is dragged along by the bridge in a tray beneath the track as shown in the left-hand side of the photograph in figure 3.

The two independent drive systems at opposite ends of the bridge are adjusted to share the drive loads equally by proper balancing of the electronic amplifiers associated with the circuitry of each system shown in figure 13. The command signal for both systems during lunar-gravity operations is derived from cable-angle sensors located on the dolly. The cable-angle signal is summed along with the first and second integral of this signal prior to being attenuated by a variable potentiometer attached to the cable drum on the dolly. The function of this potentiometer is to vary the system gain as a function of the cable length to insure system stability at all cable lengths. The potentiometer output signal is passed on through a preamplifier to the power amplifiers which drive the bridge hydraulic servocontrol valves.

When remote operation of the bridge is required for positioning the bridge and vehicle before and after each test operation, an open-loop control signal is generated by hand-operated potentiometer controls at the ground-control station.

Several mechanical, hydraulic, and electrical features are incorporated to provide safety in operation of the bridge unit. A cross shaft linking the two sides of the bridge together is used to transmit unsymmetrical loads in the event of failure of one of the drive systems. Lateral motion of the bridge is limited by a set of two spring-loaded guide rollers at each end of the bridge. These rollers engage the sides of the curbing and allow travel of about 3/4 inch (1.9 cm). This small lateral travel is required to minimize structural loads on the bridge and to allow for the variations in the track gage caused by manufacturing and erection tolerances of the gantry structure. The bridge is restrained from jumping the track by the action of the cross-shaft assembly which grips the top plate of the curbing and by the guide rollers which ride under this same plate.

The built-in hydraulic relief valves in each drive motor prevent excessive pressures and corresponding structural loads from building up in the system. Several pressure switches throughout the system detect loss of hydraulic pressure and automatically shut down the system in a safe manner. The hydraulic motors function as normal braking devices to halt the motion of the bridge, but additional braking is provided by means of expander-tube friction brakes mounted within each of the drive wheels. Braking is normally applied in a cascading sequence which begins with the pump stroker being driven to zero stroke by grounding the servo-power amplifier. At the same time, action of the friction brakes is initiated but a needle valve in the brake lines causes the full braking force to build up over about 2 seconds. At about 1.5 seconds the safety valves are released so that the pump is completely isolated from the motors and each motor can function as an independent hydraulic brake. This particular form of braking sequence insures a uniform application of the braking forces from the different braking devices and minimizes the possibility of excessive braking forces due to simultaneous operation of the devices or loss of braking action due to failure of any one device.

All electrical relays and hydraulic valves are set up so as to operate fail-safe in the event of loss of electric power. Also limit switches are installed at the extreme travel limits of the pump stokers to initiate emergency braking in case of a hard-over type of electrical or hydraulic failure. Similarly, limit switches are provided near the extremes of the bridge travel. An additional braking action is provided by mechanical buffers, located at each end of the gantry track to absorb residual bridge velocities up to 7 feet/second (2.1 m/sec).

### Dolly Unit

The dolly is a box-frame structure about 10 feet square (3 m) and 4 feet high (1.2 m), suspended on the track beneath the bridge unit by means of four sets of steel rollers mounted at the corners of the dolly. (See fig. 3.) The vertical hoist system and the cross-range drive system are mounted on the dolly frame and utilize a common 250-horsepower (186 500-watt) electric motor driving the two separate servocontrolled variable displacement pumps of each system. The principles of operation for these two systems, including the action of the braking systems, are similar to those for the bridge unit.

The power train for the cross-range drive system consists of the drive pump on the north side of the dolly and a matching 35-horsepower (26 110-watt) hydraulic motor geared to the center of a drive shaft interconnecting the two sides of the dolly. A pinion at each end of the shaft engages racks which are an integral part of the two tracks on which the dolly rides. A friction brake acting directly on the interconnecting drive shaft provides the safety backup braking for the cross-range drive system.

The power train for the vertical-hoist drive consists of the hydraulic pump and motors identical with those used in the bridge drive system. In this case, however, the pump is connected to three motors in parallel and these motors in turn are geared 4 to 1 to a common drive gear integral with the cable drum. A friction brake acts directly on the end of the cable drum opposite from the drive gear. The cable drum is grooved and provided with a level-wind mechanism and guides to prevent fouling of the two 250-foot-long (76.2 m), 7/8-inch-diameter (2.2 cm) cables. A third cable, carrying about 60 separate electrical and instrumentation wires, is wound on a separate cable drum driven by chain from the main cable drum. Each of the two main cables passes through a guide in the floor of the dolly and through the previously mentioned 5-foot-long (1.5-m) cable-angle-sensor assemblies mounted to the bottom of the dolly, as shown in figure 14. The function of the tube is to sense the angular deviations of the cables from the vertical in the two orthogonal planes aligned down range and cross range. An electrical signal proportional to the deviation in each plane is generated by rotary potentiometers geared to the gimballed mounts supporting the sensor tubes. An electrical signal proportional to the deviation in each plane is generated by rotary potentiometers geared to the gimballed mounts supporting the sensor tubes.

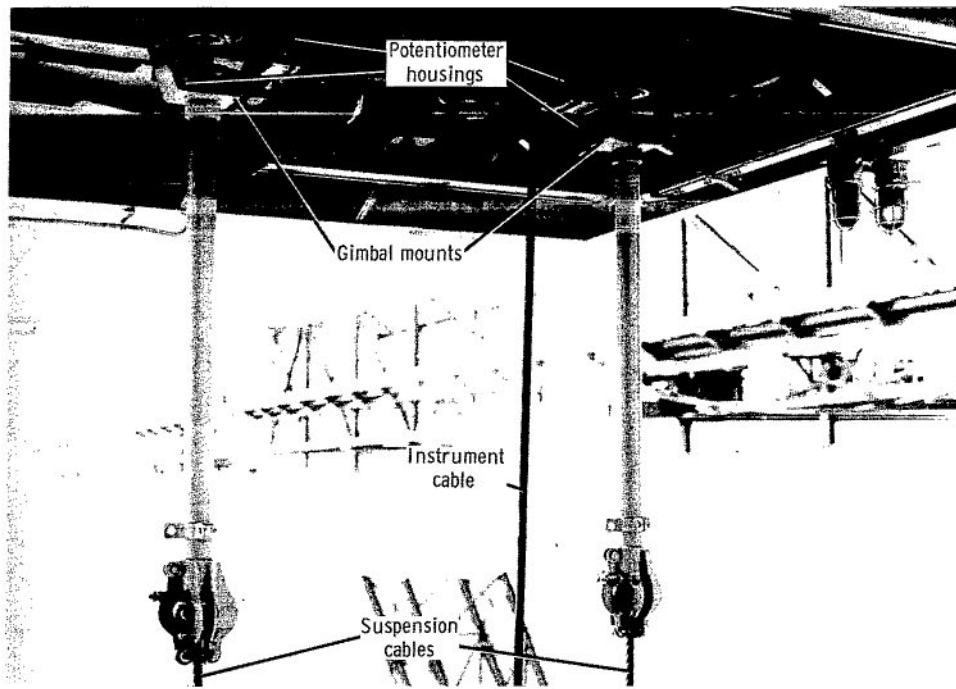

Figure 14.- Closeup of two cable-angle sensors mounted to bottom of dolly. L-66-2145.1

As shown in figure 15, the lower ends of the cables are terminated by swaged fittings attached to the vehicle gimbal support assembly, which consists of a spreader bar housing a yaw swivel unit, a pivoted rocker beam, referred to as a whiffletree, and two vertical support struts with self-aligning bearings. The function of this assembly is to transmit the cable force to the vehicle so that the force acts through the vehicle center



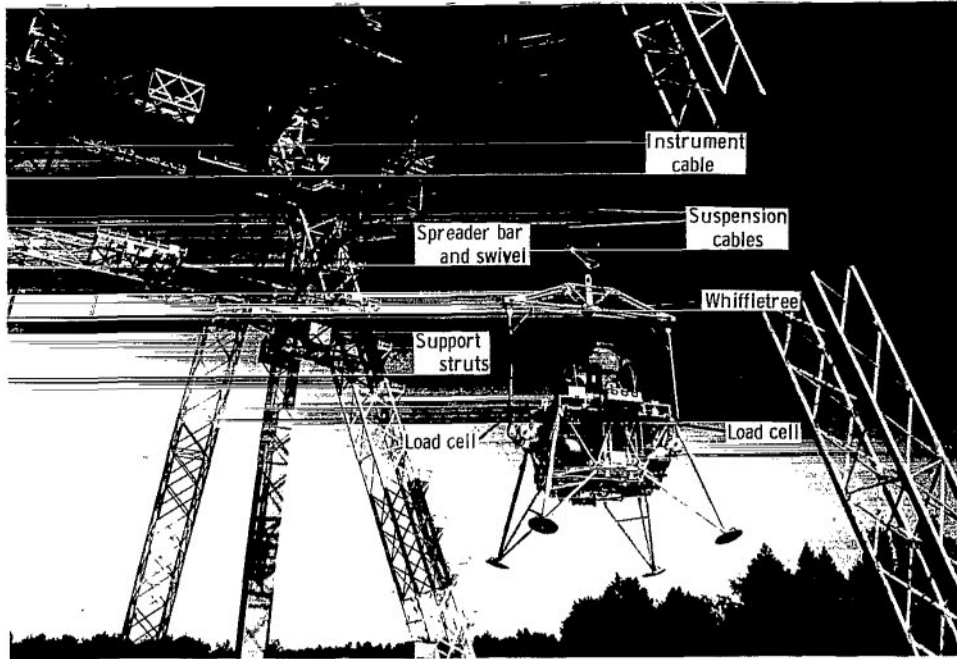

Figure 15.- Details of vehicle gimbal support assembly.

L-65-5200.1

of gravity but permits the vehicle to rotate freely about all axes within specific limits. The limits selected for operation are  $\pm 30^\circ$  in pitch and roll and  $\pm 360^\circ$  in yaw.

The load cells used to generate the electrical signals for the servocontrolled vertical hoist system are mounted in struts. The outputs of the two cells are summed electrically so as to obtain the total cable force and to eliminate any effects of rolling moments. The resultant signal is conditioned so that the vertical drive system will maintain a tension in the support cables equal to  $5/6$  the weight of the vehicle. (See fig. 16.)

#### Operational Limits

The flight envelope in this facility is illustrated in figure 17. The vehicle can be flown anywhere within a corridor 360 feet (110 m) in the down-range X-direction, 42 feet (12.8 m) crosswise in the Y-direction, and 180 feet (54.9 m) vertically in the Z-direction. The servodrive systems can follow the vehicle at velocities up to about 25 feet/second (7.6 m/sec) in the X-direction, 8 feet/second (2.4 m/sec) in the Y-direction, and 15 feet/second (4.6 m/sec) in the Z-direction.

Compensation is provided for the drag force on the vehicle and cables due to average wind velocity. There is, however, no compensation for the effect of aerodynamic moments on the control of vehicle attitude. These moments are of concern only for low angular accelerations ( $5 \text{ deg/sec}^2$  or less) with the vehicle attitude-control system; consequently, these tests are generally restricted to days when the winds are relatively calm.

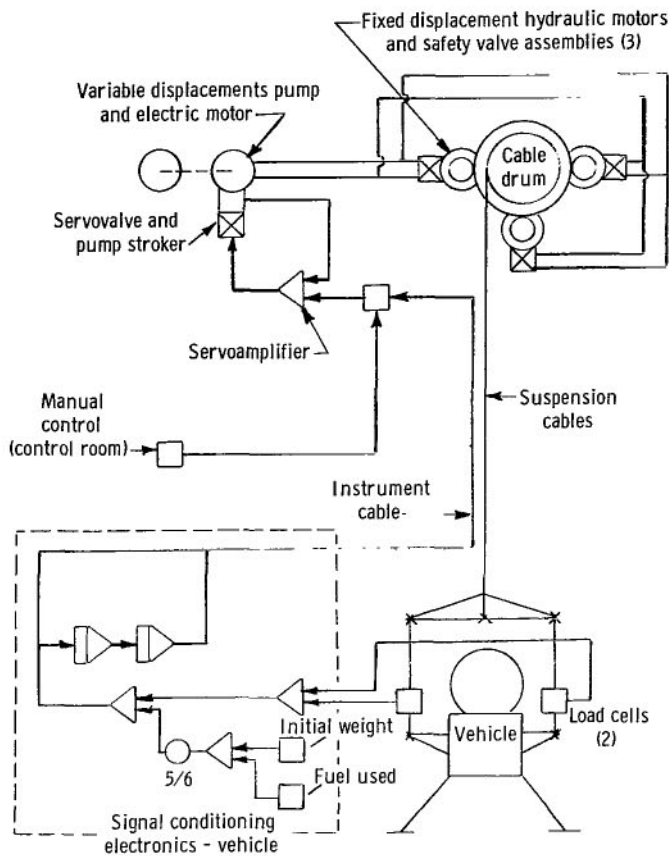

Figure 16.- Schematic diagram of vertical drive unit showing basic electronic and hydraulic circuits.

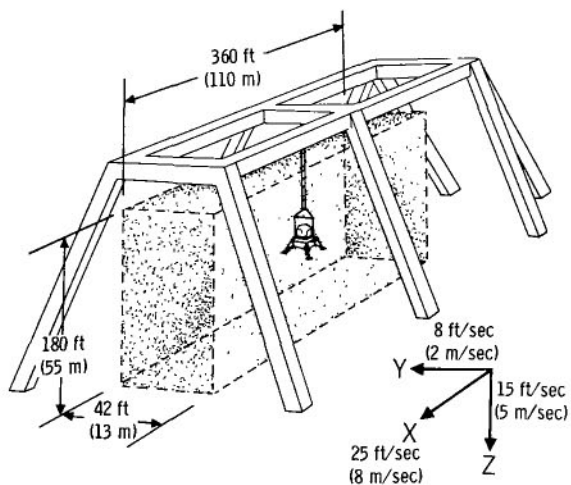

Figure 17.- Operational envelope for lunar landing research facility.

The bridge crane was designed to provide the capability of flight testing vehicles weighing up to 20 000 pounds (9072 kilograms); however, current operational limitations restrict vehicle weight to about 12 000 pounds (5443 kilograms).

## CONTROL ROOM

Operation of the facility is controlled and directed from an observation room on the second floor of the office and shop building located near the southwest corner of the gantry structure. From this vantage point movements of the vehicle, bridge, and dolly are viewed by the test director and facility operators through large observation windows. (See fig. 18.) The room is equipped with controls for manual and automatic operation of the bridge-crane drive systems. A number of instrument displays indicate the status and performance of these drive systems as well as of the vehicle itself, and three plot boards are used to indicate motions of the system relative to the safe operating limits. Although the system will disengage automatically in a safe manner when these limits are exceeded, manual controls for disengagement and subsequent braking action are provided in the control room, as well as in the vehicle, as a safety backup feature.

Two-way communications are provided throughout the facility so that the test director is in voice contact at all times with the pilot and the operational

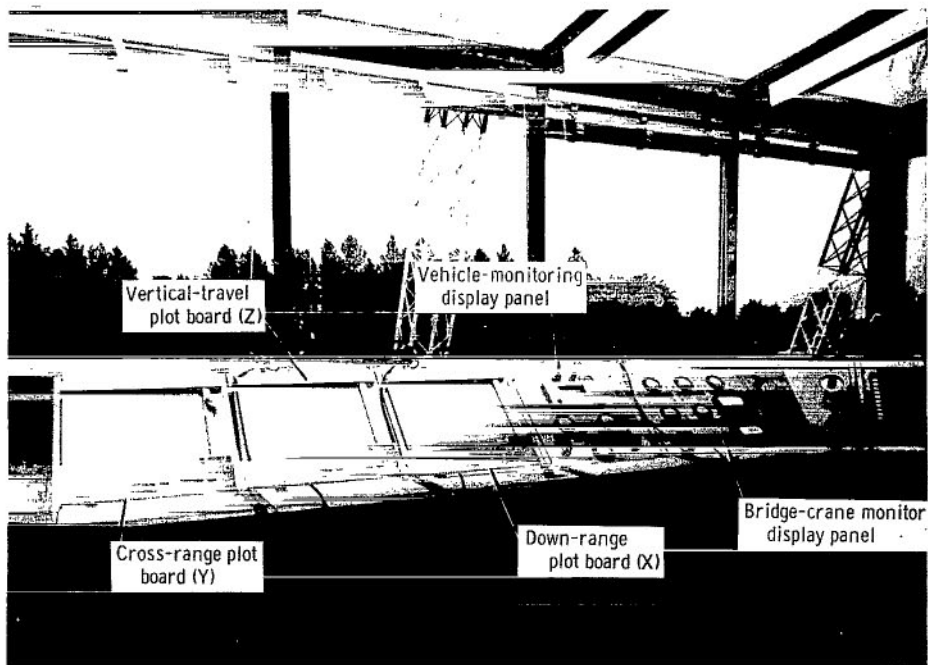

(a) View looking north.

L-64-7236.1

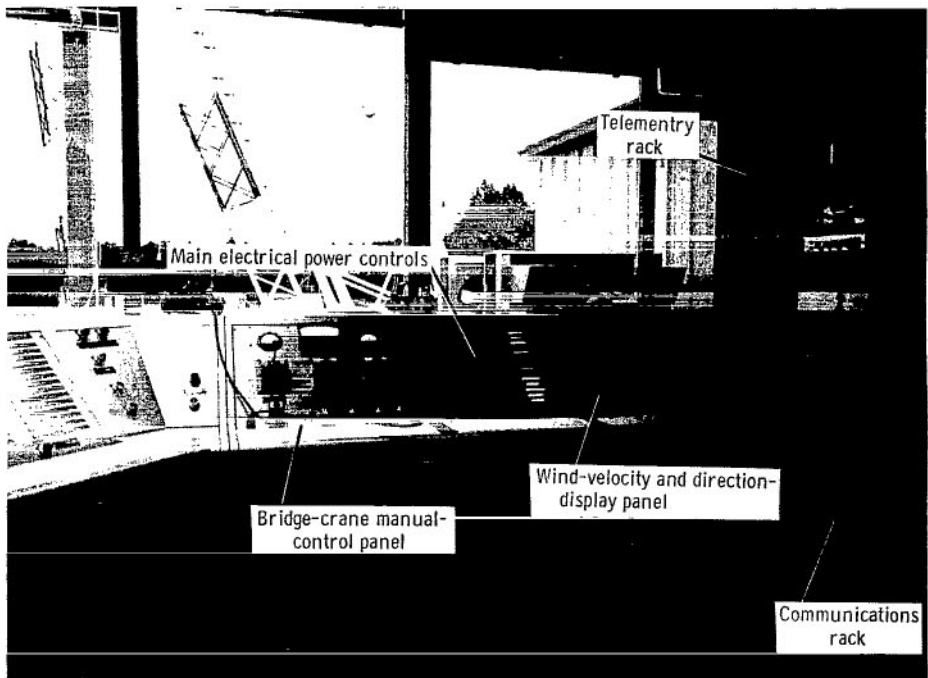

(b) View looking east.

L-64-7237.1

Figure 18.- Control-room console.

crews which service the facility and provide photographic coverage during the test operations.

### RESEARCH DATA RECORDING

Several forms of data recording are utilized so as to accumulate and retain the different types of information required in the operation of the facility and the evaluation of the flight tests. The information is used to determine that the automatic servo-operation of the facility is providing realistic lunar-gravity simulation, to show what the test pilot does to control the vehicle while performing the test maneuver, and to record the vehicle response.

In addition to the previously mentioned control-room plot boards which indicate and record the relation of positions and velocities of the bridge, dolly, and hoist, a direct-writing oscillograph is used in the control room to obtain time histories of the cable force and the cross-range and down-range angles.

Two alternate types of flight recorders are available for use on the vehicle during the tests to obtain time histories of about thirty channels of information pertaining to pilot inputs, vehicle systems operation, and vehicle response as listed in table II. The primary system is a multiplexed seven-channel magnetic tape-recorder system which permits replay of the data within a few minutes after the test run is completed so as to be of assistance during the post-flight evaluation of the flight test and debriefing of the pilot.

TABLE II.- SUMMARY OF RECORDER DATA CHANNELS  
ONBOARD THE LLRF VEHICLE

Parameter	Range
Cable force . . . . .	0 to 15 000 lbf (0 to 66 723 N)
Fuel pressure . . . . .	0 to 550 psi (0 to 3792 kN/m <sup>2</sup> )
Throttle stick position . . . . .	0° to 41°
Firing signal (each axis) . . . . .	On-off
Stick position (each axis) . . . . .	±10°
Angular acceleration (pitch and roll only) . . . . .	±30 deg/sec <sup>2</sup>
Angular velocity . . . . .	±50 deg/sec
Angular position:	
Pitch and roll . . . . .	±30°
Yaw . . . . .	±360°
Bridge velocity . . . . .	±25 ft/sec (7.62 m/sec)
Dolly velocity . . . . .	±10 ft/sec (3.05 m/sec)
Cable angle, range and cross range . . . . .	±3°

Each of the seven channels on the magnetic tape contains five channels of analog information which have been converted to frequency-modulation signals and multiplexed prior to taping. Replay of the tapes and recording of the data on visual records immediately after each flight are achieved by use of a demodulation system and the direct-writing oscillograph in the control room.

The second vehicle recording system, which is installed only when the primary system is inoperative, consists of a standard NASA oscillographic flight recorder. The individual information channels are recorded directly on a 6-inch film strip and are read out by means of semiautomatic data processing equipment, a process requiring several days.

Photographic views of the flight tests are obtained in the form of magnetic-tape-recorded television pictures and 16-millimeter motion-picture film. The television records are used for initial postflight evaluation and pilot debriefing but are not retained. The motion-picture films are used for subsequent evaluation and permanent records. Both television and film pictures are obtained from a manually operated camera station just outside the control room at the southwestern corner of the facility. Two additional manned stations for motion pictures are located at the southeast corner, one at the 50-foot (15.2 m) elevation and the other at the 150-foot (45.7 m) elevation. An additional remote camera for motion pictures of the vehicle is located in the dolly, with the camera looking straight down so as to obtain an overhead view of the vehicle relative to the ground. Direct measurements of the vehicle motions can be obtained by means of this motion picture and a calibration scale painted on the concrete apron over which the vehicle flies.

Additional photographic coverage is obtained inside the vehicle by two fixed, remotely operated motion-picture cameras to obtain records of the pilot's activities and field of vision. One 16-millimeter camera mounted on the side of the instrument panel and looking directly at the pilot's face records his head and eye motions. The second camera is located beside the pilot's head between the two seats and views the instrument panel and a portion of the window area. A mirror is located on the panel so that the motions of the pilot's right hand on the attitude controller can be seen by this camera.

Audio recordings of the flight tests are obtained by use of a tape recorder in the control room connected to the communications system. This record includes the conversations of the flight director and test pilot as well as the other facility operators who take an active part during the time the pilot is in the vehicle. An audio tape recording is also made throughout the pilot "debriefing" session subsequent to each flight operation.

## TEST OPERATIONS

The complete daily test operation is performed in essentially three phases, comprising the preflight, flight, and postflight activities. The preflight activities are concerned with ground-crew efforts to insure correct and safe operation of all subsystems and integrated units. The flight operation is concerned primarily with the activities of the test pilot, flight director, and monitoring crew to perform the specific flight-test maneuvers in accordance with the test plan and within the safe operational limits. The final postflight activities are concerned with security measures to permit safe exit of the pilot and ground handling of the vehicle for the next test flight or for storage at the end of the operational day. Some aspects of these activities are discussed in the following sections.

### Preflight Checkout

Each morning of a test day the bridge and dolly units are operated remotely from the control room and tested to all limit positions at typical operational speeds to demonstrate the adequacy of all fail-safe equipment. Following the initial checkout of the vehicle in the hangar, the vehicle is moved to the apron at the east end of the gantry by means of a tractor and special trailer. Connections are made to the gimbal suspension struts, the interconnecting instrumentation cable, and an umbilical cable which supplies power to the vehicle until the actual flight operation begins.

After the nitrogen tanks and the hydrogen peroxide tanks are loaded, the vehicle is raised about a foot (0.3 m) above the apron and final ballasting is provided to insure that the vehicle is balanced properly. A preflight check of the servo-operation of the vertical hoist is then made by raising the vehicle to an altitude of about 150 feet (45.7 m) where the system is placed into automatic operation. This action allows the vehicle to fall as the servosystem maintains the desired tension in the cables equal to  $5/6$  of the vehicle's weight. The vehicle accelerates downward with the resulting  $1/6$  earth gravity until the 15-foot-per-second (4.6 m/sec) velocity limit of the hydraulic system is reached. At this point the system is braked automatically by the limit switches on the pump stroker.

A checkout test of the bridge and dolly servosystems is performed with the vehicle resting on the ground and with the cables under tension. This test consists of displacing the bridge and dolly 2 feet (0.6 m) from directly over the vehicle so that a cable angle in each direction of about  $0.5^\circ$  is produced. The bridge and dolly drive systems are then placed into automatic operation to allow the bridge crane to realign itself over the vehicle within about  $0.05^\circ$ .

The pilot enters the vehicle by way of a removable access ladder and establishes communication with the test director through his standard flight helmet, which also hooks

into the oxygen breathing system, as soon as the servosystem checkout tests are completed. The pilot and ground crew begin activation of the vehicle flight systems in accordance with check lists and guidance of the test director. The pilot switches over to internal flight batteries and the external power umbilical is removed. The propulsion-system pressure regulators are then adjusted by the mechanics, and the fuel tanks are pressurized by the pilot. A walk-around inspection is made by a mechanic for fuel or gas leaks, after which the stable platform is activated, and all rockets are warmed up by momentary control inputs by the pilot. The vehicle is then raised clear of the ground by manual operation of the bridge crane as the pilot operates the attitude controls to maintain a level attitude. The pilot then activates the flight-recorder system and sequentially applies step inputs to each control for a system calibration. The vehicle is then moved to the desired position for the start of the flight tests, which may begin with the vehicle on the ground or at some altitude up to about 150 feet (45.7 m), depending on the particular flight-test program.

### Flight Tests

This flight-test phase of operation begins with a countdown performed by the flight director, which results, sequentially, in the safety brakes' being released by the control-room operator, the flight recorder's being turned on and the throttle adjusted to approximate hover-thrust position by the pilot, and, finally, the bridge crane's being put into automatic operation by the control-room operator. At this point the pilot is in complete command of the vehicle and initiates the flight maneuvers to carry out a preplanned flight profile. The flight director and control-room monitoring crew observe the vehicle and display instruments to evaluate the flight maneuvers relative to the safe operational limits of the facility. In the event that the limits are approached, the director either warns the pilot or stops the test, depending on the severity of the situation. The pilot may also stop the test if he becomes aware of some operational problem. Normally, however, the flight is carried to its conclusion by completing the planned flight maneuver and landing. The system is stopped or disengaged immediately by the flight director after the vehicle comes to a rest on the ground.

### Postflight and Emergency Operations

In the event that the flight is terminated by disengagement of the drive system and subsequent braking, the pendulous swing of the vehicle is permitted to subside prior to lowering the vehicle to the ground by the manual operation from the control room. If there is a malfunction in the vertical-hoist drive systems, the vehicle can be lowered by manipulation of the braking system by either the control-room operator or the crew on-board the bridge crane. A mobile cherry-picker is on standby status for use in rare emergency situations when the vehicle cannot be lowered to the ground.

With the vehicle on the ground, the pilot depressurizes the fuel and nitrogen storage tanks, and the ground crew moves in to flush down the vehicle and ground area with water to remove any traces of fuel. A fire-fighting crew and equipment are on standby status at the facility in the event of fire resulting from spilled fuel. The pilot egresses and returns to the operations building for a postflight debriefing session while the vehicle either is refueled for the next flight in about 45 minutes or is disconnected from the cables and returned to the hangar for storage at the completion of the day's operational activities.

## SYSTEM TEST RESULTS

Some results of typical operational tests of the facility are given in figures 19 to 24 to illustrate the response of the bridge crane systems, first, to step inputs used to establish optimum gains and, second, to typical pilot-controlled landing maneuvers of the vehicle used in the pilot-handling research program.

### Step-Input Response

The bridge and dolly responses are similar and are illustrated by the typical bridge test data shown in figure 19 which show the variations of the bridge velocity  $\dot{X}$  and down-range cable angle as a function of time following a step cable-angle signal equivalent

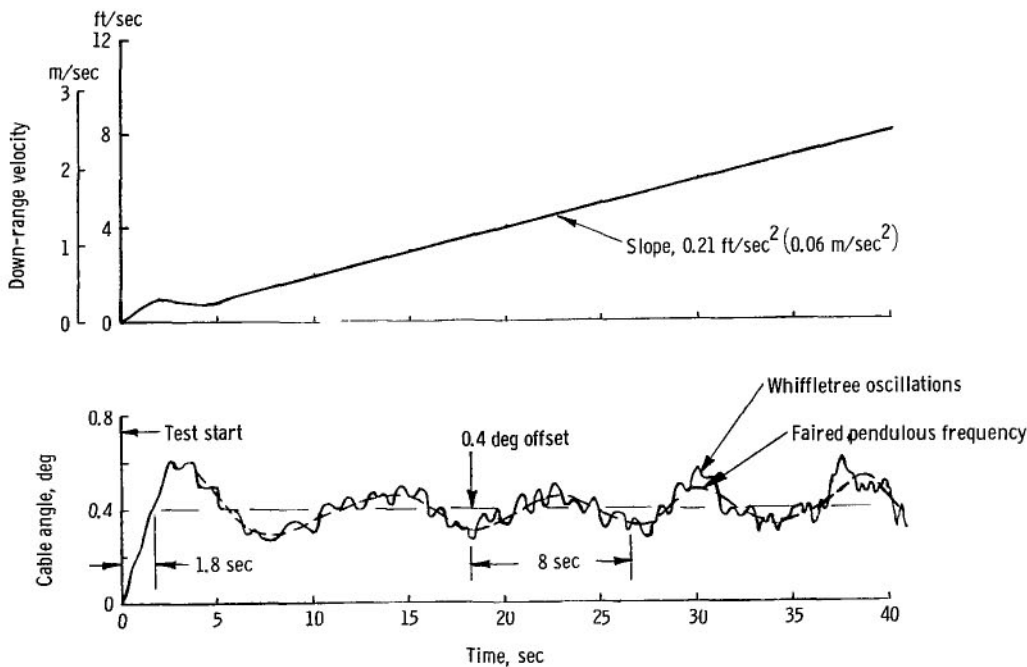

Figure 19.- Time histories of cable angle and bridge down-range velocity in response to a  $0.4^\circ$  cable-angle step input.



to about  $0.4^\circ$ . The vehicle is suspended a few feet off the ground with the dolly and hoist systems inoperative. This type of test demonstrates the ability of the bridge and dolly to maintain a desired cable angle, near  $0^\circ$ , over the full operational range of the systems. At the initiation of the test, the input signal causes the bridge to accelerate forward at about  $0.2 \text{ foot/second}^2$  ( $0.06 \text{ m/sec}^2$ ), towing the vehicle along so as to produce the commanded cable angle. The oscillographic trace of cable angle in figure 19 shows that this average angle was attained 1.8 seconds after initiation of the step input with a subsequent 50-percent overshoot of about  $0.2^\circ$ . The period of the pendulous cable oscillation was about 8 seconds or approximately half of the natural pendulous-cable period of 15.7 seconds, which occurs when the bridge servosystem is inoperative. Following the initial angle overshoot the oscillation is attenuated and the cable angle is maintained to about  $\pm 0.10^\circ$ .

Low-amplitude higher-frequency oscillations of 1 cycle per second and higher are superimposed on the pendulous-cable frequency because of the bending or whipping of the cables. The limiting factor for gain of the cable-angle signal, which provides attenuation of the pendulous motion, is the divergence of the bending frequencies which are higher than the drive-system natural frequency. Therefore, a near-optimum cable-angle gain is achieved when there is some evidence of these higher frequencies. Elimination of cable-angle error due to vehicle velocity is achieved by use of the cable-angle integral signal, but this signal has a destabilizing effect on the pendulous-cable motion; consequently, the optimum gain of the integral signal is determined by the system characteristics. The gain of the double-integral signal which eliminates the cable-angle error due to vehicle acceleration is also limited for the same basic reason.

The test of the vertical hoist system is illustrated in figure 20, which shows the oscillographic traces of vertical velocity and cable force as the vehicle is allowed to fall free under the simulated lunar gravity provided by the servocontrolled hoist. The vehicle falls until the maximum velocity is reached, at which point the system is automatically disengaged. The cable-force trace shows the decrease in cable tension to  $5/6$  the vehicle weight as the system is switched into automatic operation. The transient oscillations, primarily caused by cable stretch, are damped; and the force change is essentially unaffected as the velocity increases linearly with time to a maximum of 14.5 feet per second ( $4.42 \text{ m/sec}$ ) in 3 seconds. The average acceleration determined from the velocity trace is  $5.3 \text{ feet/second}^2$  ( $1.6 \text{ m/sec}^2$ ), which corresponds to the lunar-gravity value. The results of a series of tests to determine hoist system characteristics have indicated that it has a natural frequency of approximately 1.5 cycles per second with a damping ratio of 0.5.

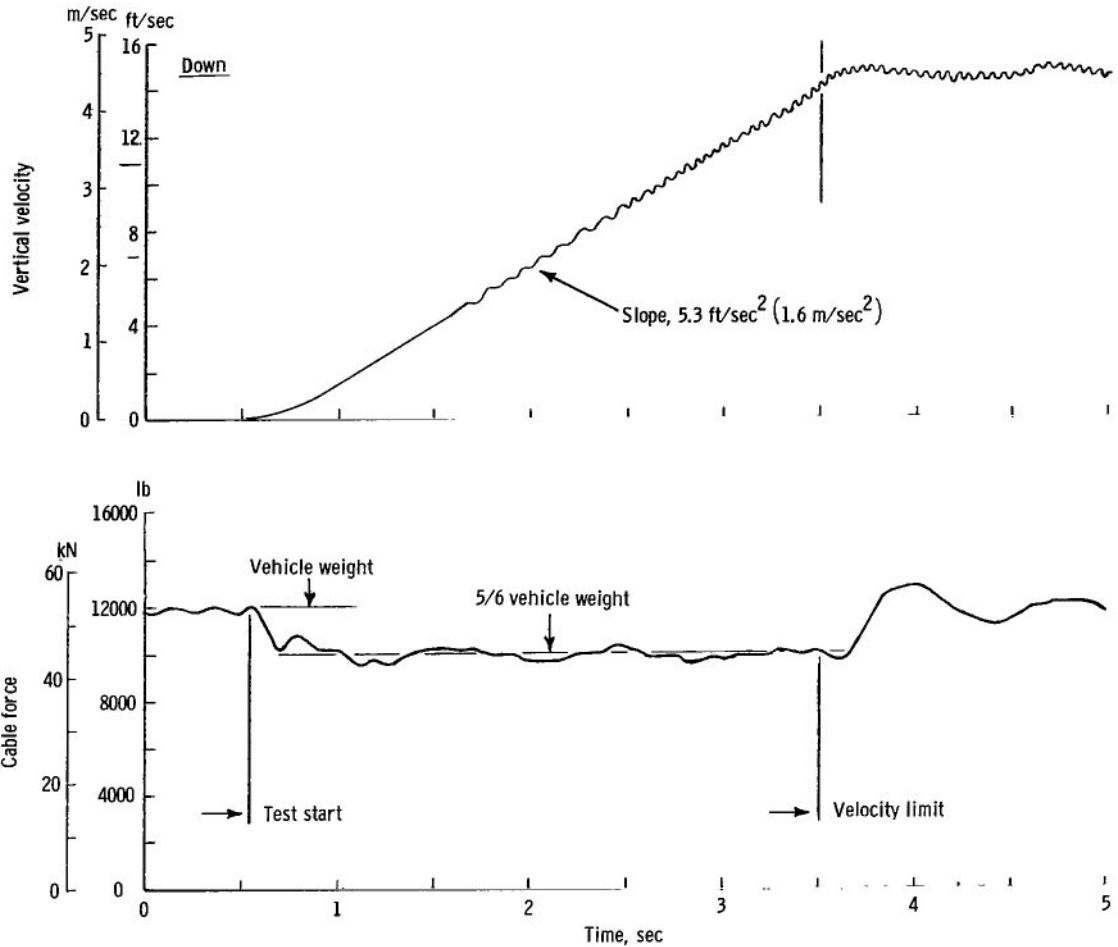

Figure 20.- Time histories of vertical velocity measured at hoist drum and cable force measured at vehicle in response to a free-fall test during simulated lunar-gravity operation.

### Flight-Maneuver Response

The trajectory of a typical landing from an altitude of about 100 feet (30 m) and a horizontal distance of 180 feet (55 m) from the landing spot is shown in figure 21, which is an X-Z coordinate plot of the flight path with 5-second time intervals marked along the path. Time histories of the down-range velocity, down-range cable angle, cable force, and vertical velocity for this same flight test are presented in figure 22. The flight was initiated from a hovering condition as the pilot elected to generate a vertical descent prior to pitching over to move forward to the designated landing target. The vehicle was pitched down to accelerate forward at about 0.3 foot per second per second (0.09 m/sec<sup>2</sup>) from 5 seconds to 27 seconds during which time the cable angle deviated from the vertical by no more than 1/3°. For the interval from 27 seconds to touchdown, the vehicle was pitched up to provide deceleration from a maximum down-range velocity of 5.8 feet per second (1.8 m/sec). The cable angle reversed direction but did not exceed the value

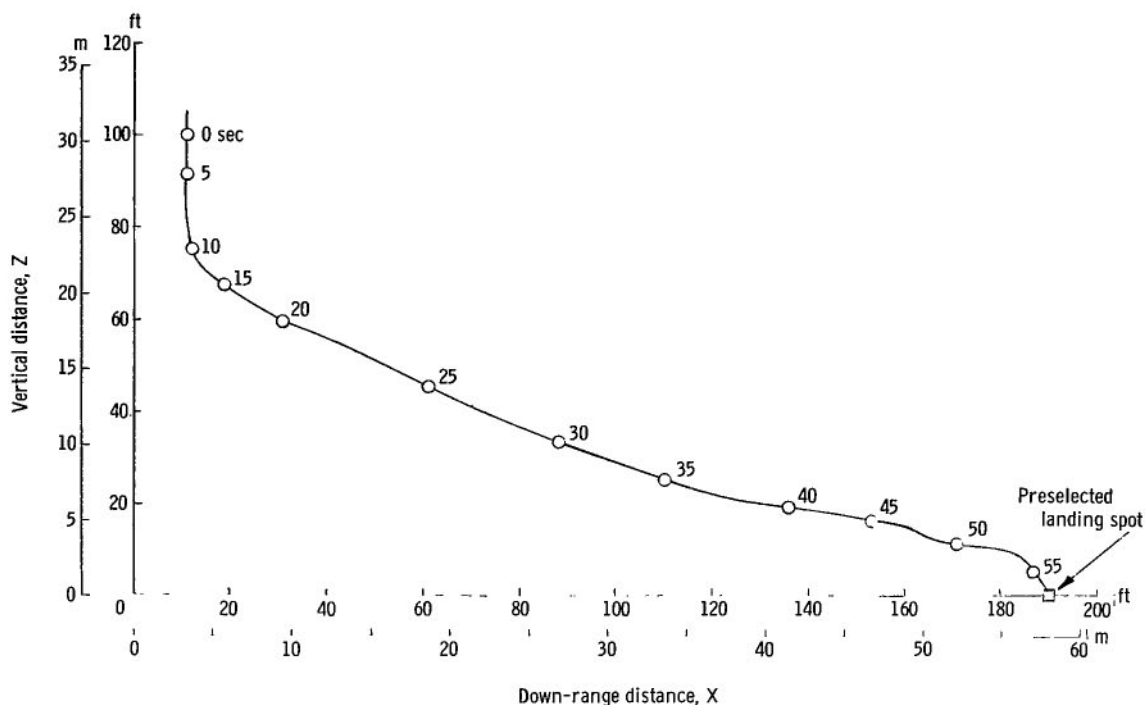

Figure 21.- Typical flight-path profile of research vehicle performing a landing maneuver from altitude of about 100 feet (30 meters) and 180 feet (55 meters) away from the selected down-range landing spot.

of  $0.3g$ . The pilot made many corrections of the main lifting engine thrust throughout the landing maneuver as is indicated by the abrupt changes in the slopes of the vertical-velocity—time-history curve. These changes correspond to vertical accelerations of about 3 feet per second per second ( $0.9 \text{ meter/sec}^2$ ) downward to 1.5 feet per second per second ( $0.45 \text{ meter/sec}^2$ ) upward. These acceleration changes, in turn, represent vertical thrust changes of about 1200 pounds (5338 N) downward and 600 pounds (2669 N) upward. The time-history curve of cable force reveals that, aside from the small cable-stretch oscillations induced by the rather abrupt thrust changes, the cable force is unaffected by the large vertical motion of the vehicle. The cable force slowly decreases in response to the vehicle-weight change resulting from fuel consumption. The average ratio of cable force to vehicle weight remains constant at  $5/6$  throughout the flight. Transient oscillations equivalent to  $\pm 0.3$  lunar "g's" occur during flights, as indicated in figure 22; however, the pilots have generally been unable to perceive these oscillations.

The relation of these typical flight motions relative to the operational limits of the facility are illustrated in figures 23 and 24 which are the safety monitoring records displayed in the control room by two of the plot boards discussed previously. Figure 23 shows the altitude—vertical-velocity plot with the superimposed vertical operational boundaries, which denote a maximum descent velocity of 14 feet per second (4.3 m/sec), and a maximum ascent velocity of 13 feet per second (4.0 m/sec). The slanted portions

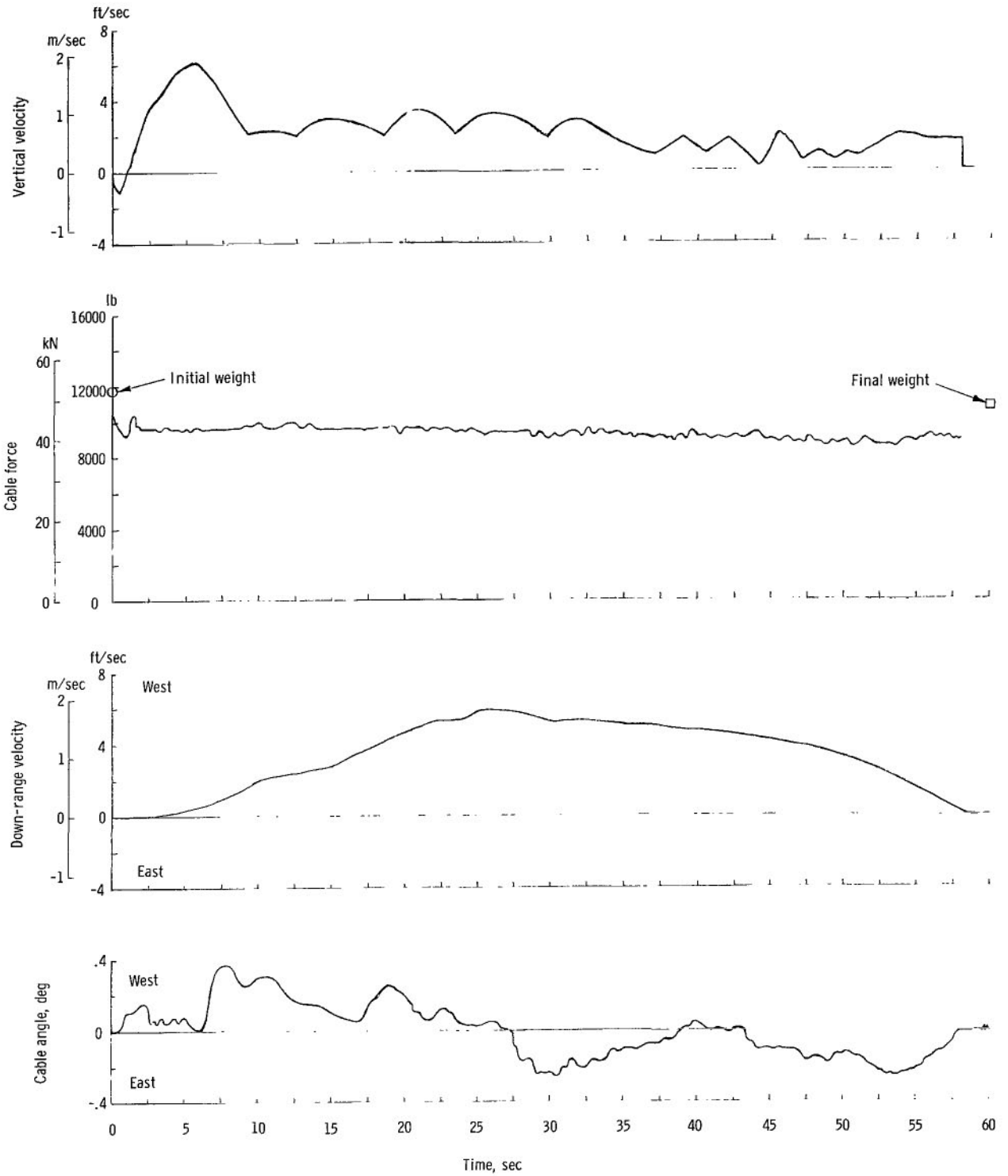

Figure 22.- Time histories of vertical velocity, cable force, down-range velocity, and cable angle for landing maneuver shown in figure 21.

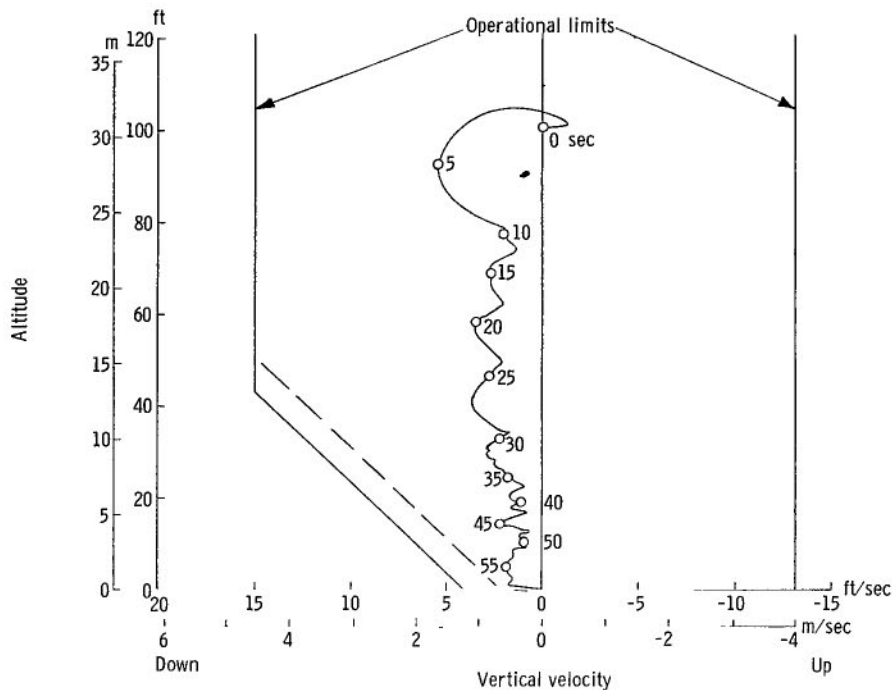

Figure 23.- Altitude-vertical-velocity plot obtained from control-room plot board showing motions of typical landing maneuver (figs. 21 and 22) relative to operational limits of facility.

of the boundaries represent the braking and driving capabilities of the hoist. The slanted solid line in the "down" side of the plot corresponds to the velocity-exceed boundary which automatically disengages the system when the limit line is exceeded. The dashed line is used as a warning boundary for the control-room plot-board monitor. The flight-test trace reflects the altitude and velocity changes shown in the previous figure and illustrates that the pilot was able to perform the flight maneuver well within the operational limits of the system.

The plot of down-range velocity as a function of distance down range in figure 24 illustrates the operational limits for the bridge system. These limits do not represent the maximum capabilities discussed previously but have been employed to provide extra margin of safety during initial operation of the facility. The flight-test trace shows that maneuvers similar to this particular flight can be performed well within these operational limits.

There were no significant cross-range excursions for this test as the pilot was maintaining flight primarily in the XZ-plane. In other flight tests, particularly those where lateral translation and yawing maneuvers have been performed, the maximum available cross-range limits of  $\pm 21$  feet (6.4 m) have been encountered usually after the

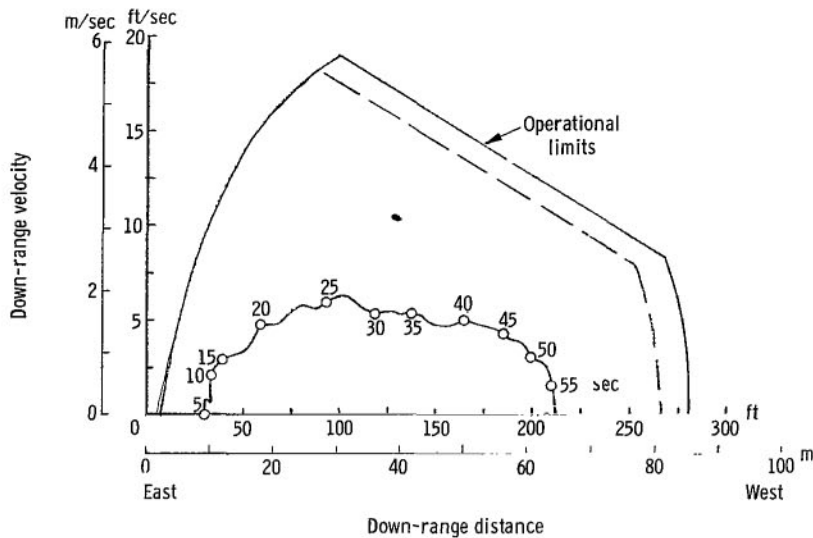

Figure 24.- Variation of down-range velocity with distance obtained from control-room plot board showing motions of typical landing maneuver (figs. 21 and 22) relative to operational limits of facility.

pilot has initiated attempts to correct the overtravel condition. To avoid disengagement of the system and discontinuance of an otherwise satisfactory flight test when such a situation occurs, a modification to the normal automatic operation has been incorporated so as to permit continuation of the flight so long as all systems are operating normally. This modification, which in effect provides a cushioning action, consists of a set of switches which slow the dolly to a halt without disengaging any of the systems as the dolly approaches within 2 feet (0.6 m) of the normal extreme travel-limit switches. This action permits the pilot to complete the corrective actions and bring the vehicle back to the desired flight path and continue with the remaining flight maneuver. In the event that the pilot has failed to take a corrective action and approaches these switches at an excessive speed, the dolly will slow as these switches are encountered but will also overtravel and strike the extreme-limit switches, disengaging the system and applying braking action.

#### Observations on Facility Operations

On the basis of nearly a hundred manned flight tests in which eight research pilots and astronauts have been used as pilot test subjects, the following general observations and comments relative to the facility operation can be made:

(1) The servocontrolled bridge, dolly, and vertical-hoist systems operate satisfactorily to produce the desired vertical lifting force on the flight vehicle and thereby simulate the effects of lunar gravity on the vehicle flight behavior.

(2) The pilots, without exception, have reported sensations of actual free flight and are unable to detect artifacts attributable to the servocontrolled system during normal flight-test operations.

(3) The physical operational limits of the facility have imposed only minor constraints on the pilot's ability to perform landing tasks. The primary constraint has been the total available cross-range travel of 42 feet (12.8 meters) which has generally required somewhat more attention on the part of the pilot to lateral drift than might be required otherwise.

(4) The visual obstruction or cues imposed by the gantry structure appear to have a negligible effect on the pilot's ability to perform a typical landing task.

(5) Utilization of the simulated main-thrust mode of operation is very useful for the indoctrination of new pilot test subjects and for performing exploratory research flights with untried combinations of control-system parameters and vehicle design features.

(6) The facility appears to be practical for continued research into the flight behavior and pilot handling characteristics of not only the Apollo lunar module but also other vehicles proposed for operation in lunar and other subgravity environments. With only minor modifications to the suspension fittings and adjustments of the servosystem, the facility can be utilized for studies of lunar roving vehicles, rocket propulsion backpacks for lunar and space operations, and Mars or Venus rocket-propelled landing vehicles.

#### CONCLUDING REMARKS

Design features and operational characteristics of the lunar landing research facility at the Langley Research Center have been discussed. Results of a typical flight test are included to illustrate the capabilities of the facility in simulating lunar gravity. Observations based on reports of nine pilots, including three astronauts, from nearly 100 flight tests indicate this facility to be a practical research tool for assessing the flight behavior and handling characteristics of space vehicles proposed for operation in subgravity environments.

Langley Research Center,  
National Aeronautics and Space Administration,  
Langley Station, Hampton, Va., October 19, 1966,  
125-19-01-13-23.

## REFERENCES

1. Bellman, Donald R.; and Matranga, Gene J.: Design and Operational Characteristics of a Lunar Landing Research Vehicle. NASA TN D-3023, 1965.
2. Boisseau, Peter C.; Schade, Robert O.; Champine, Robert A.; and Elkins, Henry C.: Preliminary Investigation of the Handling Qualities of a Vehicle in a Simulated Lunar Gravitational Field. NASA TN D-2636, 1965.
3. Mechtly, E. A.: The International System of Units - Physical Constants and Conversion Factors. NASA SP-7012, 1964.



*"The aeronautical and space activities of the United States shall be conducted so as to contribute . . . to the expansion of human knowledge of phenomena in the atmosphere and space. The Administration shall provide for the widest practicable and appropriate dissemination of information concerning its activities and the results thereof."*

—NATIONAL AERONAUTICS AND SPACE ACT OF 1958

## NASA SCIENTIFIC AND TECHNICAL PUBLICATIONS

**TECHNICAL REPORTS:** Scientific and technical information considered important, complete, and a lasting contribution to existing knowledge.

**TECHNICAL NOTES:** Information less broad in scope but nevertheless of importance as a contribution to existing knowledge.

**TECHNICAL MEMORANDUMS:** Information receiving limited distribution because of preliminary data, security classification, or other reasons.

**CONTRACTOR REPORTS:** Technical information generated in connection with a NASA contract or grant and released under NASA auspices.

**TECHNICAL TRANSLATIONS:** Information published in a foreign language considered to merit NASA distribution in English.

**TECHNICAL REPRINTS:** Information derived from NASA activities and initially published in the form of journal articles.

**SPECIAL PUBLICATIONS:** Information derived from or of value to NASA activities but not necessarily reporting the results of individual NASA-programmed scientific efforts. Publications include conference proceedings, monographs, data compilations, handbooks, sourcebooks, and special bibliographies.

*Details on the availability of these publications may be obtained from:*

SCIENTIFIC AND TECHNICAL INFORMATION DIVISION  
NATIONAL AERONAUTICS AND SPACE ADMINISTRATION  
Washington, D.C. 20546